



SOUTH FORT COLLINS SANITATION DISTRICT

STANDARD CONSTRUCTION SPECIFICATIONS

December 2010

Revision 1.04

TABLE OF CONTENTS

SUMMARY OF WORK

GENERAL

1.1	Scope	01010-1
1.2	Specifications Documents	01010-2
1.3	Coordination with the District	01010-4
1.4	Work Sequence	01010-4
1.5	Notifications	01010-4
1.6	Safety and Protection	01010-5
1.7	Special Requirements	01010-5
1.8	Quality Control	01010-7

MATERIALS, EQUIPMENT AND WORKMANSHIP

GENERAL

1.1	Description	01600-1
1.2	Materials and Equipment	01600-1

TESTING SANITARY SEWER SYSTEM

GENERAL

1.1	Description	01666-1
1.2	Air Testing Sanitary Sewer Mains	01666-1
1.3	Vacuum Testing Manholes	01666-2
1.4	Televising Sanitary Sewer Mains	01666-3

SITE CLEANUP

GENERAL

1.1	Description	01710-1
1.2	Execution	01710-1
1.3	Disposal	01710-2

PROJECT RECORD DRAWINGS

GENERAL

1.1	Project Record Drawings	01720-1
1.2	Maintenance of Project Record Drawings	01720-1
1.3	Submission	01720-2

TRENCHING, BACKFILLING AND COMPACTING

GENERAL

1.1	Description	02221-1
1.2	Quality Assurance	02221-1
1.3	Job Conditions	02221-2
1.4	Maintenance and Correction	02221-3

MATERIALS

2.1	Stabilization Material	02221-4
2.2	Bedding Materials	02221-4
2.3	Ground Water Barriers	02221-4
2.4	Trench Backfill Material	02221-5

EXECUTION

3.1	Preparation	02221-5
3.2	Trenching	02221-5
3.3	Pipe Bedding	02221-7
3.4	Ground Water Barriers	02221-7
3.5	Backfilling and Compaction	02221-8
3.6	Field Quality Control	02221-9

PIPE BORING AND JACKING

GENERAL

1.1	Description	02224-1
1.2	Quality Assurances	02224-1

PRODUCTS

2.1	Casing Pipe - Smooth Steel	02224-1
2.2	Accessories	02224-2

EXECUTION

- | | | |
|-----|---------------------------|---------|
| 3.1 | Casing Installation | 02224-3 |
| 3.2 | Carrier Pipe Installation | 02224-4 |

PAVEMENT REPAIR AND RESURFACING

GENERAL

- | | | |
|-----|-------------|---------|
| 1.1 | Description | 02575-1 |
|-----|-------------|---------|

MATERIALS

- | | | |
|-----|---------------------------------|---------|
| 2.1 | Aggregate, Asphalt and Concrete | 02575-1 |
|-----|---------------------------------|---------|

EXECUTION

- | | | |
|-----|--|---------|
| 3.1 | Manhole Rings | 02575-1 |
| 3.2 | Asphalt and Concrete, Base and Gravel Surfaces | 02575-2 |
| 3.3 | Field Quality Control | 02575-2 |

MANHOLES

GENERAL

- | | | |
|-----|--|---------|
| 1.1 | Description | 02605-1 |
| 1.2 | Product Delivery, Storage and Handling | 02605-1 |

PRODUCTS

- | | | |
|-----|---------------------------|---------|
| 2.1 | Precast Concrete Manholes | 02605-1 |
| 2.2 | Cast-In-Place-Manholes | 02605-2 |
| 2.3 | Mortar | 02605-2 |
| 2.4 | Grout | 02605-2 |
| 2.5 | Ring and Cover | 02605-3 |
| 2.6 | Steps | 02605-3 |
| 2.7 | Preformed Plastic Gaskets | 02605-3 |
| 2.8 | Pipe Penetration Gaskets | 02605-3 |

EXECUTION

- | | | |
|-----|--------------|---------|
| 3.1 | Installation | 02605-4 |
|-----|--------------|---------|

PLASTIC GRAVITY SEWER PIPE

GENERAL

- | | | |
|-----|--|---------|
| 1.1 | Description | 02622-1 |
| 1.2 | Product Delivery, Storage and Handling | 02622-1 |

PRODUCTS

- | | | |
|-----|----------------------------|---------|
| 2.1 | Plastic Gravity Sewer Pipe | 02622-2 |
| 2.2 | Joints | 02622-2 |

EXECUTION

- | | | |
|-----|--------------|---------|
| 3.1 | Installation | 02622-2 |
|-----|--------------|---------|

SANITARY SEWER COLLECTION SYSTEM

GENERAL

- | | | |
|-----|--|---------|
| 1.1 | Description | 02722-1 |
| 1.2 | Quality Assurance | 02722-1 |
| 1.3 | Product Delivery, Storage and Handling | 02722-1 |
| 1.4 | Job Conditions | 02722-1 |

PRODUCTS

- | | | |
|-----|----------------------------|---------|
| 2.1 | Manholes | 02722-2 |
| 2.2 | Plastic Gravity Sewer Pipe | 02722-2 |

EXECUTION

- | | | |
|-----|----------------------|---------|
| 3.1 | Inspection | 02722-2 |
| 3.2 | Preparation | 02722-2 |
| 3.3 | Pipe Installation | 02722-3 |
| 3.4 | Manhole Installation | 02722-4 |
| 3.5 | Service Connections | 02722-5 |

CAST-IN-PLACE CONCRETE

GENERAL

- | | | |
|-----|-------------|---------|
| 1.1 | Description | 03300-1 |
|-----|-------------|---------|

MATERIALS

2.1	Cement	03300-1
2.2	Aggregates	03300-1
2.3	Water	03300-1
2.4	Admixtures	03300-1
2.5	Concrete Reinforcement	03300-2

CONCRETE

3.1	General	03300-3
3.2	Placing	03300-3
3.3	Finishing	03300-4
3.4	Curing	03300-4

PRECAST CONCRETE

GENERAL

1.1	Description	03400-1
1.2	Product Delivery, Storage and Handling	03400-1

PRODUCTS

2.1	Precast Concrete Products	03400-1
-----	---------------------------	---------

APPENDIX

Typical Drawings

SECTION 01010

SUMMARY OF WORK

PART 1 - GENERAL

1.1 SCOPE

- A. The purpose of this document is to set forth the South Fort Collins Sanitation Districts' criteria for the construction of 15-inch and smaller sewer mains, sewer services and all appurtenances associated with these mains and services. It is for the use of owners, developers, design engineers, and contractors as guidelines for the construction of said mains, services, and appurtenances.
 - 1. In the case of sewer mains which are larger than fifteen (15) inches, the Owner, or the Owner's representative, shall submit construction specifications and drawings to the District for review.
- B. These specifications are intended to be sufficiently detailed to provide adequate definition of the work to be performed and to insure the quality of that work.
 - 1. The Contractor and/or his representative shall be responsible for understanding the provisions and the content of these Specifications.
- C. These specifications are composed of written Material Specifications and Standard Drawings. The final interpretation of these specifications shall be made by the South Fort Collins Sanitation District.
 - 1. Every attempt shall be made to avoid conflicts between the standards and drawings during design. However, when requested in writing the South Fort Collins Sanitation District shall provide a letter of interpretation.
- D. In the event that a conflict occurs between sanitary sewer mains, services, and other utilities, as identified during construction, the Contractor shall contact the South Fort Collins Sanitation District to interpret these specifications or to determine if the standards of other utilities or departments apply.

1.2 SPECIFICATION DOCUMENTS

A. Definitions.

1. AASHTO - American Association of State Highway and Transportation Officials.
2. ACI - American Concrete Institute.
3. ANSI - American National Standards Institute.
4. ASTM - American Society for Testing and Materials.
5. CCTV - Closed Circuit Television, A television system often used for pipeline inspection.
6. CDOH STANDARDS - Colorado Department of Highways Standard Specifications for Road and Bridge Construction.
7. CONSTRUCTION DRAWINGS - Detailed and working drawings, including plan, profile, and detail sheets of proposed utility improvements, approved by the Engineer.
8. CONTRACTOR - An individual who has entered into an Agreement with the Owner to perform the work.
9. DESIGN ENGINEER - The partnership, corporation, or individual who is registered as a professional engineer, according to Colorado statutes, and who is hired by the owner, and is empowered to act as his agent for the project.
10. DISTRICT ENGINEER - Shall mean the District Engineer of the South Fort Collins Sanitation District or their authorized representative.
11. DISTRICT - The South Fort Collins Sanitation District
12. OSHA - Occupational Safety and Health Administration.
13. OR AN APPROVED EQUAL - As approved, in writing, to being equal by the District.
14. OWNER - The developer, corporation, association, partnership, or individual who has entered into an agreement with the District and has entered into an agreement with the contractor to perform the work.
15. PROVIDE - Furnish and install complete in place.

16. **RECORD DRAWINGS** - Detailed drawings that show actual construction and contains field dimensions, elevations, details, changes made to the construction drawings by modification, details which were not included on the construction drawings, and horizontal and vertical locations of underground utilities.
 - a. Record Drawings are usually construction drawings which have been modified to contain the information listed above.
17. **REMOVE** - Remove and dispose of in a manner consistent with local ordinances, laws and regulations.
18. **SERVICE LINE** - All pipe, fittings and appurtenances for conveying wastewater from the customer's premises to the collection main.
19. **SHALL** - A mandatory condition.
20. **DISTRICT ENGINEER** - Shall mean the District Engineer of the South Fort Collins Sanitation District or their authorized representative.
21. **TAP** - The physical connection to the distribution main.
22. **WORK** - The entire completed construction or the various separately identifiable parts required to be furnished for the project. Work is the result of performing services, furnishing the labor and furnishing and incorporating materials and equipment into the construction.

B. Interpretation

1. These Specification's contain many command sentences which are directed at the Contractor unless otherwise stated.
2. The Contractor shall request clarification, in writing to the District, of all apparent conflicts. The District will not be responsible for any explanations, interpretations, or supplementary data provided by others.
3. Most recent issue of standards.

1.3 COORDINATION WITH THE DISTRICT

- A. The Contractor is responsible for coordinating a pre-construction meeting with the District.
- B. The Contractor is responsible for coordinating the work with the District.

- C. Connections to existing pipelines.
 - 1. All connections to existing sewer mains shall be made at a time authorized by the District.

1.4 WORK SEQUENCE

- A. Contractor shall coordinate the sequence of activities, taking into account work by others; possible easement requirements; permit requirements; and District requirements.
- B. Contractor shall coordinate the beginning of work, excavation near ditches, railroads, road cuts, etc. with the District, affected parties, and utilities prior to beginning construction.
- C. Contractor shall coordinate activities such as, but not limited to, backfilling operations, air testing, vacuum testing, CCTV, and moisture/density testing with the District.

1.5 NOTIFICATIONS

- A. Contractor shall contact the District, all utilities and affected parties at least 48 hours (exclusive of holidays and weekends) prior to working in areas adjacent to underground utilities.
- B. Contractor shall verify vertical and horizontal locations of all existing utilities prior to installation of District facilities.
- C. Contractor shall give the District a minimum of 48 hours notice (exclusive of holidays and weekends) prior to commencement of work, see previous page.
- D. Contractor shall coordinate all inspections and testing with the District Representative.

1.6 SAFETY AND PROTECTION

- A. Contractor shall be responsible for initiating, maintaining and supervising all safety precautions and programs in connection with the work. Contractor shall take all reasonable and necessary precautions for the safety of, and shall provide the necessary protection to prevent damage, injury or loss to:
 - 1. Employees and other persons onsite who may be affected.
 - 2. The work and materials or equipment to be incorporated therein, whether in storage on or off the site.

3. Other property at the site or adjacent thereto, including, but not limited to trees, shrubs, lawns, walks, pavements, roadways, structures and utilities not designated for removal, relocation or replacement in the course of construction.

B. Contractor shall comply with all applicable laws, ordinances, rules, regulations and orders of any public body having jurisdiction for the safety of persons or property or to protect them from damage, injury or loss; and shall erect and maintain all necessary safeguards for such safety and protection.

1.7 SPECIAL REQUIREMENTS

A. All items and work not covered by these specifications shall be discussed with the District, and the Contractor shall receive approval from the District, in writing, prior to beginning work.

B. All work must be acceptable by the District prior to being placed in service.

C. District furnished material.

1. When the District furnishes any materials, the Contractor shall be responsible for such materials once they have been picked up or delivered to the job site.

2. The Contractor shall be responsible for the careful inspection of 'District furnished material' at the time of delivery.

3. Contractor shall repair, in a manner acceptable to the District, or replace any 'District furnished material', which has been damaged or stolen, at the Contractor's expense.

4. The District is responsible for the quality and operational design aspects of 'District furnished material'.

D. Contractor shall warrant all work, for a period of one (1) year, after final completion and District acceptance of the work.

1. Contractor may perform such maintenance and repairs by subcontract.

a. If the Subcontractor chooses to subcontract the warranty work, he shall submit to the District a copy of the subcontract or the work authorization as evidence of the contractor's faithful intention during the one (1) year warranty period.

E. Field changes from the approved plans shall not be permitted without prior permission from the District.

- F. The Developer, Developer's Engineer, or Developer's Contractor is responsible to coordinate a pre-construction meeting with the District at least five (5) days, exclusive of holidays and weekends, prior to construction.
- G. The Developer, Developer's Engineer or Developer's Contractor is responsible to submit three (3) sets of approved Construction Drawings to the District at least five (5) days, exclusive of holidays and weekends, prior to the pre-construction meeting.
- H. The Developer shall be responsible for the cost of re-tests, excessive inspection and inspection during non-office hours. Office hours are 7:00 a.m. to 3:30 p.m., Monday through Friday, exclusive of holidays. The District will notify the Contractor when such costs are being incurred.
- I. No work shall take place on weekends or holidays without prior authorization from the District.
- J. Contractor shall provide all materials, equipment and other items required to isolate and accomplish total separation of new construction from existing facilities.
- K. Prior to commencing work, Contractor shall designate, in writing, an authorized representative who shall have complete authority to represent the Contractor and shall be on the construction site at all times during work activities.

1.8 QUALITY CONTROL

- A. Inspection.
 - 1. The District shall make periodic checks to verify the quality and progress of the work. The authorized agents and their representatives of the District shall be provided safe access to the work, whenever it is in preparation or progress. The Contractor shall provide for such access and for inspection, including maintenance of temporary and permanent access.
 - 2. Materials and equipment rejected by the District shall be identified and marked for removal for the Contractor or Supplier.

END OF SECTION

SECTION 01600

MATERIAL, EQUIPMENT AND WORKMANSHIP

PART 1 - GENERAL

1.1 DESCRIPTION

- A. This section addresses the material, equipment, and workmanship needed to complete the installation of the sewer main and all associated appurtenances.

1.2 MATERIALS AND EQUIPMENT

- A. Contractor shall furnish all materials, equipment, labor, and incidentals necessary for the execution, testing, and completion of the work.
- B. All materials and equipment shall be of good quality and new, except as otherwise approved by the District.
 - 1. When requested by the District, the Contractor shall furnish satisfactory evidence (including manufacturer's certification) as to the kind and quality of materials and equipment, and their compliance with these specifications.
 - a. The District shall test any manufacturer's material it deems necessary.
 - b. It is the Contractor's responsibility to insure the manufacturer's materials supplied meet these specifications.
 - 2. Prior to using existing materials, approval must be obtained from the District, in writing.
- C. All materials and equipment shall be installed and used in accordance with the instructions of the applicable manufacturer, fabricator, supplier or distributor, except as otherwise provided in these specifications.
- D. The specification of materials and equipment shall be understood to be representative of a quality of performance, operation and construction acceptable to the District.
 - 1. The District shall make every effort to evaluate all written requests for the product substitution within thirty (30) days.
 - a. Such requests shall include detailed product literature and a description of benefits which might be achieved by this substitution.

- E. In approving materials or equipment for installation, the District assumes no responsibility for injury or claims resulting from failure of the materials or equipment to comply with the applicable National, State, and local safety codes or requirements, or the safety requirements of a recognized agency; or failure due to faulty design concepts, or defective workmanship.

END OF SECTION

SECTION 01666

TESTING SANITARY SEWER SYSTEMS

PART 1 - GENERAL

1.1 DESCRIPTION

- A. This section concerns the testing of sanitary sewer collection mains and manholes.
- B. All manholes are required to be Vacuum tested.
 - 1. Vacuum testing shall occur after completion of soil backfilling and compaction.
- C. All pipe shall be subjected to a low pressure air test.
 - 1. A test section shall not be any longer than the length of pipe between adjacent manholes.
 - 2. Air tests shall be conducted on all sewer mains and service lines.
 - 3. The low pressure air test shall occur after completion of soil backfilling and compaction.
- D. If, the CCTV inspection of the sewer main identifies a problem, the District may require alignment, infiltration, exfiltration and/or deflection tests, as needed.
- E. The contractor shall provide all equipment and personnel to perform the required tests.
- F. The District shall record times, pressure, and vacuum readings during the test period.

1.2 AIR TESTING SANITARY SEWER MAINS

- A. The ends of the sewer pipe being tested shall be plugged and braced.
- B. The length of pipe being tested shall be pressurized to a minimum of 3.5 psi.
- C. The pressure pump shall be turned-off and the time monitored.

- D. The pressure must not drop more than one (1) psi, for the amount of time indicated by using the following formula:

$$T = 0.0237 L D^2$$

Where T = time of test (in seconds)
 L = length of pipe being tested (in feet),
 D = diameter of pipe (in inches).

- E. Sections of the pipe which fail the air test shall have the defects repaired, and the test shall be repeated.
 - 1. The failed section of pipe shall be repaired and retested until the testing requirements are met.

1.3 VACUUM TESTING MANHOLES

- A. Manholes shall be tested before the ring, cover, and grade adjustment rings are installed.
- B. All pipes entering the manhole shall be plugged and braced.
 - 1. Service laterals entering manhole shall be tested with the manhole.
- C. A vacuum of ten (10) inches of mercury shall be drawn.
- D. The vacuum pump shall be turned-off and the time monitored.
 - 1. The vacuum shall not drop more than one (1) inch of mercury for the duration of the time indicated in the following table:

*Specified Test Duration for Diameter of Manhole
 (duration indicated in minutes: seconds)*

Manhole Diameter (inches)		
<u>48</u>	<u>60</u>	<u>72</u>
1:00	1:15	1:30

- E. Manholes with infiltration will not be tested until repairs have been made from outside of the manhole.

- F. Manholes which fail the vacuum test shall have the defects located and repaired from the outside of the manhole, and the test shall be repeated.
 - 1. The failed manhole shall be repaired and retested until the testing requirements are met.

1.4 TELEVISIONING SANITARY SEWER MAINS

- A. All sanitary sewer lines shall be televised and submitted, to the District, for approval prior to first lift of asphalt.
 - 1. The recording shall be made using a self-propelled, color camera having sufficient light to show detail.
 - 2. The camera shall have a pan-and-tilt head capable of viewing sewer service laterals.
 - 3. The camera speed shall not exceed three (3) feet per second.
 - 4. Sewer mains shall be flushed and clean of debris prior to televising.
 - 5. All recordings shall have location (I.E. manhole number to manhole number), time, date, and footage displayed.
 - 6. All televised recordings shall be submitted in DVD format.
 - 7. All DVD's shall be legibly labeled with company, project, and pertinent televising information.

END OF SECTION

SECTION 01710

SITE CLEANUP

PART 1 - GENERAL

1.1 DESCRIPTION

- A. Site cleanup shall be executed during the progress of the work, and at the completion of the work.

1.2 EXECUTION

- A. Construction materials shall be neatly stored.
- B. Containers shall be provided for the collection of wasted material and debris.
 - 1. Containers shall be stored out of the right-of-way.
- C. Volatile wastes shall be stored in clearly marked, covered metal containers and removed daily.
- D. Construction materials, equipment, waste containers, construction buildings, parking, etc., shall only be allowed within the limits of the construction easement.
 - 1. Any off-site storage of construction material, equipment, waste containers, construction buildings, parking, etc. shall be allowed only after the Contractor has obtained the written permission of the property owner.
- E. Upon completion of the construction, the job site shall be restored to its original condition or better.
 - 1. Contractor shall restore any land which will not be paved with asphalt, or concrete, to its original condition.
 - a. All topsoil shall be restored to its original quality.
 - b. Any areas which are stripped of vegetation prior to, or during construction, shall be reseeded.
 - 2. All exterior paved surfaces shall be broom cleaned, and left in good repair.

1.3 DISPOSAL

- A. In order to maintain an orderly site, waste material and debris shall be removed periodically.

END OF SECTION

SECTION 01720

PROJECT RECORDS DRAWINGS

PART 1 - GENERAL

1.1 CERTIFIED DRAWING OF RECORD

- A. Certified Record Drawings shall be submitted by the Design Engineer to the District Engineer for review and approval.
- B. Each drawing shall be labeled "DRAWINGS OF RECORD" in neat large printed letters, stamped and signed by a registered P.E. for the State of Colorado.
- C. Construction information shall be recorded concurrently with construction progress.
- D. Record Drawings shall be marked legibly and with an indelible pen.
- E. Record Drawings shall include, as a minimum, the following:
 - 1. Field dimensions, elevations, and details.
 - 2. Changes which are made by modification.
 - 3. Details which are not on the original Construction Drawings.
 - 4. Horizontal and vertical locations of underground utilities and appurtenances, referenced to a minimum of three permanent surface improvements.
 - 5. Depths of various elements of work in relation to project datum.
 - 6. All dimensions shall be referenced to property pins if surface improvements have not been constructed.

1.2 MAINTENANCE OF PROJECT RECORD DRAWINGS DURING CONSTRUCTION

- A. Record Drawings and any documents used for the preparation of said Drawings shall be stored apart from documents used for construction.
- B. Record Drawings shall be maintained in a clean, dry, legible condition and in good order.

1.3 SUBMISSION

- A. Project Record Drawings shall be submitted to the District Engineer with a transmittal letter containing the following:
 - 1. Date.
 - 2. Project title.
 - 3. Design Engineer's name, address and telephone number.
 - 4. Title and number of each Record Document.
- B. Project Record Drawings shall be submitted on 24" x 36", 3 mil (minimum) reproducible, double-matte Mylar, along with electronic Auto-CAD files on compact disc.
- C. The final acceptance of the sewer lines and appurtenances will not be made until all District requirements are satisfied and the Project Record Drawings are received and accepted by the District.
- D. The District recommends that Project Record Drawings be submitted in blue line form for preliminary approval.

END OF SECTION

SECTION 02221

TRENCHING, BACKFILLING AND COMPACTING

PART 1 - GENERAL

1.1 DESCRIPTION

- A. This section addresses excavation and trenching; including subsurface drainage, dewatering, preparation of subgrades, pipe bedding, ground water barriers, backfilling, compacting, and finish grading for underground pipelines, service lines and appurtenances.
- B. Reference the "Standard Trench and Bedding Detail" in the appendix.

1.2 QUALITY ASSURANCE

- A. Soil compaction tests shall be performed in accordance with:
 - 1. ASTM D698 - Standard Method of Test for Moisture Density Relations of Soil.
 - 2. ASTM D4253 & D4254 – Standard Method of Test for Relative Density of Cohesionless Soils.
- B. Construction Staking.
 - 1. Construction staking shall be performed under the supervision of a Colorado licensed Land Surveyor.
 - 2. All survey notes and construction staking notes shall be entered into bound, hard cover field books.
 - 3. Adequate staking shall be provided to establish acceptable horizontal and vertical control.
 - 4. Offsets shall be staked so that vertical and horizontal alignment may be checked.
 - 5. All survey data, which is developed by the Contractor, the Developers Engineer, and the Surveyor, shall be available, on request, to the District for examination during the construction period.

1.3 JOB CONDITIONS

A. Drainage and Groundwater.

1. Contractor shall obtain all necessary permits prior to starting dewatering operations.
2. Any water which is encountered in the trench shall be removed to the extent necessary to provide a firm subgrade, to permit connections, and to prevent the entrance of water into the pipeline.
3. Surface runoff shall be diverted as necessary to keep excavations and trenches free from water during construction.
4. The excavation or trench shall be kept free from water until the structure, or pipe, to be installed therein, is completed to the extent that no damage from hydrostatic pressure, flotation, or other cause will result.
5. Water shall be prevented from entering any sewer pipe which is already in service and has been accepted by the District.
6. The pipe under construction shall not be used for dewatering, without the written approval of the District.

B. Sequencing.

1. Pipeline installation shall be performed within 400 linear feet of trench excavation.
 - a. If construction is occurring in an open field, this distance may be amended, at the District's discretion.
2. Initial trench backfill shall be performed within 50 linear feet of pipeline installation.
 - a. If construction is occurring in an open field, this distance may be amended, at the District's discretion.
3. Backfilling and compaction of the trench shall be in progress to within four manholes of that portion of the sewer that is being constructed, unless authorized by the District.
4. Where excavation is a hazard to automotive or pedestrian traffic, the amount of open trench and the time duration of that opening is to be coordinated with the appropriate authority's discretion.

C. Underground Obstructions.

1. The Design Engineer, Developer and/or Contractor shall field verify all Record Drawing information obtained from the District.
2. Contractor shall notify each Utility Owner and request utilities to be field located by surface reference at least 48 hours prior to trenching or excavating.
3. The Contractor shall expose and verify the size, location, and elevation of underground utilities and other obstructions, sufficiently in advance of construction to permit changes to be made to the Construction Drawings.
 - a. In the event there is a conflict, the Contractor shall notify the District and the affected utility company.
 - b. In the event there is a conflict, the proposed work may be modified, at the District's discretion.
4. Existing improvements, adjacent property, utilities, trees, and plants that are not to be removed shall be protected from injury or damage resulting from the Contractor's operations.
5. If the Contractor removes any underground obstructions, the area in which the underground obstruction was located shall be restored to the original condition, or better.

1.4 MAINTENANCE AND CORRECTION

- A. Contractor shall maintain and repair all trench settlement and make necessary repairs to damaged pavement, sidewalks or other structures.
 1. Contractor shall warrant work for a period of one (1) year after final completion and acceptance of the work.
- B. Contractor may perform such maintenance and repairs by subcontract.
 1. If the Contractor chooses to subcontract the warranty work, they shall submit to the District, a copy of the subcontract, or the work authorization, as evidence of the Contractor's faithful intention to perform any repairs which may become necessary during the one (1) year warranty period.

PART 2 - MATERIALS

2.1 STABILIZATION MATERIAL

- A. If the existing soil in the trench bottom is judged to be unsuitable by the District, a minimum of the top six (6) inches of the pipe subgrade shall be removed and replaced with a stabilization material.

1. Stabilization material is crusher-run rock, conforming to ASTM D448, or CDOH #357.

<i>SIZE</i>	<i>PERCENT PASSING</i>
2"	95 - 100
1"	35 - 70
1/2"	10 - 30
#4	0 - 5

- a. Or an approved substitute.
- B. Geosynthetics may be used in conjunction with stabilization material, with the prior approval of the District.

2.2 BEDDING ZONE MATERIALS

- A. Pipe shall be bedded in a uniformly graded material, conforming to CDOH #67.

<i>SIZE</i>	<i>PERCENT PASSING</i>
1"	100
3/4"	90 - 100
3/8"	20 - 55
#4	0 - 10
#8	0 - 5

2.3 GROUND WATER BARRIERS

- A. If clay is used for ground water barriers, it shall meet the following soil classification.
1. SC - clayey sands, sand-clay mixtures.
 2. CL - inorganic clays of low to medium plasticity, gravelly clays, sandy clays, silty clays, lean clays.

3. CH - inorganic clays of high plasticity, fat clays.

B. Concrete used for ground water barriers shall develop a minimum compressive strength of 2,000 psi after twenty eight (28) days.

2.4 TRENCH BACKFILL MATERIAL

A. Trench backfill material shall be placed from a point twelve (12) inches above the pipe to twelve (12) inches below the ground surface or to the bottom of the pavement subgrade, whichever is greater.

B. Trench backfill material shall be either soil excavated from the trench, or imported soil.

1. Any soil used for trench backfill, shall be free from frozen matter, stumps, roots, brush, other organic matter, cinders or other corrosive material, debris, and any rocks or stones which are larger than six (6) inches, in any dimension.

a. Rocks or stones which are six (6) inches or larger may be used in the trench backfill material with prior approval of the District.

2. If imported soil is used for trench backfill, it shall meet CDOH specifications for Class #2 structural backfill.

PART 3 - EXECUTION

3.1 PREPARATION

A. Topsoil shall be stripped from areas which are to be disturbed by construction, and stockpiled.

1. Topsoil shall be segregated from non-organic trench excavation material, and debris.

3.2 TRENCHING

A. Trenches shall be excavated by open cut methods, except where boring or tunneling is shown on drawings, and is approved by the District.

B. Trench width shall be maintained to within three (3) inches of that specified on plans or as otherwise directed by the District.

C. Care shall be used when operating mechanical equipment in locations where it may cause damage to trees, buildings, culverts, or other existing property, utilities, or structures above or below ground.

- D. Mechanical equipment shall be operated in such a manner that the bottom elevation of the trench can be maintained with uniform trench widths and vertical sidewalls of the bedding zone.
 - 1. Contractor shall follow the most current regulations concerning excavations set forth by OSHA; Title 29 CFR part 1926.

- E. Trench alignment shall be sufficiently accurate to permit pipe to be aligned properly with an eight (8) inch minimum clearance between the pipe and the sidewalls of the trench or trench box.
 - 1. The trench sidewall shall not be undercut in order to obtain clearance.

- F. The Contractor shall over-excavate a minimum of six (6) inches, or as directed by the District, below the bottom of the pipe wherever the trench bottom is rock, or other unsuitable material.
 - 1. Over-excavation shall be backfilled and compacted with acceptable Granular Material.
 - a. Reference paragraph 2.2 A.

- G. Preparation of trench bottom.
 - 1. Trench bottom shall be graded uniformly to provide clearance for each section of pipe.
 - 2. Loose material, water, and foreign objects shall be removed from the trench.
 - 3. The contractor shall provide a firm subgrade, which is suitable for application of bedding material.
 - 4. Wherever unstable material is encountered in the bottom of the trench, said material shall be over-excavated to a depth suitable for construction of a stable subgrade, as determined by the District.
 - a. The depth suitable for construction shall be determined by the District.
 - b. The over-excavation shall be backfilled with stabilization material and compacted and/or placed as required by the District.
 - i. Reference Part 2.1 of this section.

H. Stockpiling excavated materials.

1. Suitable material for backfilling shall be stockpiled in an orderly manner, and stored a minimum of two (2) feet from the edge of the trench.
2. The Contractor shall be responsible for disposal of excess excavated materials not suitable or not required for backfilling.
3. Excavated material shall not be stockpiled against or over existing structures or appurtenances.

3.3 PIPE BEDDING

A. Placement and compaction.

1. Reference the "Standard Trench and Bedding Detail" in the appendix.
2. Bedding material shall be distributed and graded to provide uniform and continuous support beneath the sewer main and all service at all points between bell ends, or pipe joints.
 - a. Pipe shall not be supported by the bells.
 - b. A minimum of four (4) inches of bedding shall be placed prior to the installation of the sewer main and services.
3. To prevent lateral displacement, granular bedding material shall be deposited and compacted uniformly and simultaneously on each side of the pipe.
 - a. Bedding material shall not be dropped onto unsupported pipe.
4. Granular bedding material shall be consolidated under and around the pipe.

3.4 GROUND WATER BARRIERS

A. Ground water barriers shall be constructed in such a manner as to impede passage of water through bedding material for the full depth of the granular bedding material, and the full width of the trench.

1. Ground water barriers shall be approximately four (4) feet long and spaced not more than four hundred (400) feet apart. Ground water barriers shall be placed generally on the up gradient side of the manhole unless otherwise directed by the District.

2. Ground water barriers shall extend to a point two (2) feet above the existing ground water level.
 - a. If the ground water barrier is near an irrigation ditch, pond, stream, or other waterway, the barrier shall extend to a point one (1) foot above the 100-year water level.

3.5 BACKFILLING AND COMPACTION

- A. All trench backfill shall be compacted.
 1. Backfill of pipe and appurtenances and around manholes shall be compacted with equipment and in a manner which is capable of producing the required results.
- B. Backfill material shall be deposited in uniform horizontal layers which shall not exceed six (6) inches (compacted depth), in all areas.
 1. Other thickness may be used with the approval of the District.
- C. Methods and equipment which are appropriate for the backfill of material shall be employed.
 1. Backfill equipment or backfilling methods which damage the pipe shall not be used.
- D. Compaction shall not be performed by jetting or water settling.
- E. Sheeting removal (if Contractor elects to use sheeting).
 1. Do not remove sheeting prior to backfilling.
 2. Use effective methods to protect the construction, other structures, utilities and property during sheeting removal.
 3. Voids left by sheeting removal shall be filled with dry sand.
 4. Sheeting which is left in place shall be cut off at an elevation eighteen (18) inches below the finish grade of unpaved areas, or twelve (12) inches below the subgrade of paved areas.
- F. Topsoil shall be replaced to the original depth over all areas which are to be reseeded.
- G. Excess excavated material and materials not suitable for backfill shall be disposed of properly.

3.6 FIELD QUALITY CONTROL

A. Field moisture/density control.

1. Field tests will be conducted to determine compliance of moisture/density testing methods with specified density in accordance with ASTM D2922 (Tests for Density of Soil and Soil-Aggregate In Place by Nuclear Methods).
2. Moisture/density tests are the responsibility of the Contractor, and shall be performed by a private Geotechnical Consultant.
 - a. The method of testing of the compacted material and the validity of the results shall be the responsibility of the Geotechnical Consultant certifying the testing.
 - b. Test results shall be submitted to the District by the Contractor or the Geotechnical Consultant the day of the test.
 - i. Copies of the field work sheets are acceptable.
 - c. Summarized test results shall be submitted to the District prior to the initial acceptance of the sewer system.
 - d. The District may elect to perform backfill density testing for compliance of the work with the public rights-of-way.
3. Results of all moisture/density tests shall be submitted to and approved by the District prior to acceptance of the sewer main and available on the job site on the day of the test.
4. Moisture/density tests shall be performed at a minimum of two (2) feet above the top of the pipe bedding and in two (2) foot vertical increments up to the finish grade.
5. Moisture/density test shall be performed at a minimum of 200 linear feet, as measured along the length of the pipe, or as determined by the District.
6. Moisture/density tests in the vicinity of manholes shall be performed at a maximum of one (1) foot away from the manhole section.
 - a. A test shall be made in all four directions from the manhole
 - b. A minimum of one (1) test shall be performed for every two (2) feet of backfill material.

7. Moisture/density tests shall be performed below the finished subgrade, and a minimum of one time for each service line installation.
 8. All failed test areas shall be re-compacted and retested.
- B. Compaction shall be to the following minimum densities: (Reference ASTM D 698 or AASHTO T99 unless otherwise indicated).
1. Ground water barrier material: 95% of maximum density (ASTM D 698).
 2. Pipe bedding.
 - a. Compacted granular material: 80% of relative density (ASTM D 4253 and D 4254).
 3. Trench backfill.
 - a. Paved roadways, sidewalks and other areas which are to be paved: 95% of maximum density.
 - i. The initial lift above the pipe (which is not to exceed three (3) feet) may be compacted to 90% of maximum density.
 - ii. A minimum of four (4) feet of trench shall be compacted to 95% of maximum density.
 - b. Gravel roadways: 95% of maximum density.
 - c. Fields and landscaped areas: 90% of maximum density.
 - d. All other locations: 95% of maximum density.
 - e. A concrete cap shall be required over the sewer main in instances where the distance from the top of the pipe to the finished surface of the ground is less than four (4) feet.

C. Moisture content.

1. All compacted backfill shall be within a minimum of 2% (+/-) of the optimum moisture content of the soil as determined by ASTM D 698.
2. Water shall be added to the material, or the material shall be harrowed, disked, bladed, or otherwise worked to insure uniform moisture content, as specified.
3. Expansive soils may require higher moisture content, as determined through laboratory test performed by a Geotechnical Engineer.

END OF SECTION

SECTION 02224

PIPE BORING AND JACKING

PART 1 - GENERAL

1.1 DESCRIPTION

- A. This section is a minimum guideline and addresses the furnishing and the installation of casing pipe, either by boring or jacking.
- B. Each casing pipe installation shall be specifically designed by the Design Engineer.
- C. Reference the "Standard Pipe Casing Detail" in the appendix.

1.2 QUALITY ASSURANCES

- A. Design Criteria.
 - 1. Specified thickness for pipe and casings are based upon the superimposed loads and not upon the loads which may be placed on the pipe as a result of jacking operations.
 - a. Increased pipe strength shall be provided as necessary to withstand jacking loads.
- B. Construction Criteria.
 - 1. Owner/Contractor shall obtain the necessary permits from the appropriate agencies, prior to commencing construction.
 - 2. Owner/Contractor shall obtain the bonds or the indemnity which are required by the permits, for protection against any damage and interference with traffic and service, which are caused by the construction activities.
 - 3. All excavations shall conform to the trenching, backfilling and compaction requirements set forth in Section 02221.

PART 2 - PRODUCTS

2.1 CASING PIPE - SMOOTH STEEL

- A. The minimum yield point of smooth steel casing pipe shall be 35,000 psi.

- B. Smooth steel casing pipe shall conform to ASTM 139, Grade B (No hydro).
 - 1. Clean used pipe which is in good condition, and conforms to the requirements of this specification may be used with the prior approval of the Design Engineer and District.
- C. The minimum wall thickness of smooth steel casing pipe shall be determined by the agency granting the crossing permit.
 - 1. Reference the "Standard Pipe Casing Detail" in the appendix.
- D. The ends of smooth steel casing pipe shall be beveled for field welding.
 - 1. All field welds shall be painted with an epoxy polyamide exterior coating, or a coal-tar enamel exterior coating, which conforms to AWWA C203, Section 2.
 - a. The minimum thickness of the exterior coating shall be sixteen (16) mil.
- E. Smooth steel casing pipe shall have an epoxy polyamide exterior coating, or when required by the Construction Drawings, a coal-tar enamel exterior coating.
 - 1. If the Contractor elects to omit the exterior coating, 1/16 inch shall be added to the required thickness of the casing pipe.

2.2 ACCESSORIES

- A. Casing Seals.
 - 1. Casing seals shall be constructed of high density rubber with stainless steel straps.
 - a. The acceptable type and manufacturer of high density rubber casing seals are:
 - i. Link-Seal modular seal, model "C" or "S" wrap around end seal with stainless steel bands, Pipeline Seal and Insulator, Inc.
 - ii. Or an approved equal.
- B. Casing chocks.
 - 1. Casing chocks shall be twelve (12) inches in length with stainless steel bodies and polymer runners. There shall be three (3) per joint.

- a. Acceptable manufacturers are:
 - i. Cascade Water Works.
 - ii. Power Seal.
 - iii. Or an approved equal.
2. The carrier pipe barrel shall be supported in accordance with the "Standard Pipe Casing Detail", see appendix, and as modified on the approved Construction Drawings.

C. Joint Restraints

1. Joint restraint is required on the carrier pipe joints in accordance with the "Standard Pipe Casing Details", see appendix, and as modified on the approved Construction Drawings.
 - a. Acceptable manufacturers are:
 - i. Ford UFR1390-P Restraint
 - ii. Or an approved equal.

PART 3 - EXECUTION

3.1 CASING INSTALLATION

A. General.

1. Vertical and horizontal offset staking shall be provided at both ends of bored or jacked crossings.
2. Casing pipe shall be installed at the grade and alignment shown on the Construction Drawings.
 - a. Grade and alignment shall not deviate by more than 0.3 feet from that shown on the Construction Drawings.
3. Casing pipe shall be installed as indicated in the Construction Drawings, whether that is by open trench excavation or by jacking methods.
 - a. Open trench installation of the casing pipe shall be in accordance with Section 02221.
4. The earth which is displaced by the casing pipe shall be disposed of properly.

B. Smooth Steel Pipe.

1. Contractor shall provide a smooth, continuous, and uniform casing pipe with no exterior voids.
2. Each section of casing pipe shall be welded with a full penetration butt weld around the entire circumference of the joint to form a watertight continuous conduit capable of resisting all stresses, including jacking stresses.

02224-3

3. A seventeen (17) pound high potential magnesium anode shall be installed at each end of the casing pipe, using a cadweld method.

C. Grouting.

1. All spaces between the casing pipe and the earth shall be filled with grout.
 - a. Grout connections on the interior of the casing pipe shall be provided at ten (10) feet (O.C.) intervals.
2. Grouting operations shall be performed in a sequence which will preclude any deflections which exceed 5 per cent of the tunnel diameter.
3. After the grout is in place, each hole shall be plugged in order to prevent the backflow of grout.

3.2 CARRIER PIPE INSTALLATION

- A. Carrier pipe shall be installed at the grade shown on the Construction Drawings.
- B. Each section of pipe shall have a minimum of three (3) casing chocks.
- C. Carrier pipes that exceed 20 L.F. shall have mechanical joint restraints installed at each joint.
- D. The annular space between the casing and the carrier pipes shall be left vacant.
- E. The ends of the casing pipe shall be sealed with casing seals.

3.3 CATHODIC PROTECTION

- A. Soil-Test Evaluation

1. In all cases the Design Engineer must have a certified Geotechnical Engineer perform a soil-test evaluation in strict accordance with AWWA C105, Appendix A. The results and recommendations of the evaluation shall be submitted to the District for consideration and review.
2. The Water-Saturated Soil Box method shall be used to measure the resistivity of the soil.
3. The distance between sample locations shall be at the discretion of the District.

02224-4

4. If the soil-test evaluation concludes that the soil is corrosive to steel casing pipe, the Design Engineer must submit a comprehensive plan with a proposed design for cathodic protection. The design shall be in accordance with the National Association of Corrosion Engineers (NACE RP0169 latest revisions).

B. Magnesium Anodes

1. One anode shall be installed at each end of the casing pipe.
2. Anodes shall be installed vertically in native soils, a minimum of three feet laterally from the pipe to be protected.
3. Place the top of the anode below the centerline of the pipe. However, anode spacing and lateral distance can be adjusted to maintain adequate clearance from permanent structures and obstacles with the approval of the District.
4. Anodes shall be backfilled and tamped with native soil in 6 inch layers. Sand is not permissible.
5. Wet down each anodes with 5 gallons, minimum, of fresh water after backfilling and tamping.

C. Wiring

1. Underground wires, cables and connections shall be buried with 6 inch minimum separation from other underground structures.
2. Splices and repairs to damaged cable associations with a cathodic protection system shall be sealed against moisture penetration using 2-1/2 lapped layers of tape alternating between rubber and plastic tape.
3. Wiring shall be backfilled with material free from rocks and debris that could damage the insulation.

D. Brazing (cadweld)

1. Brazing techniques shall comply with the anode manufacture's recommendations. Only proper size cartridges and welders will be permissible.
2. Prior to brazing, an area of the structure three inches square shall be cleaned to bright metal with a grinder or file.
3. The slag shall be removed from the completed braze with a hammer.

02224-5

4. The adequacy of each braze shall be demonstrated by gently striking the top of the connection with a one pound hammer.
5. The cleaned piping surface, including the brazed connection and exposed copper wire, shall be coated with a coal tar compound.

E. Test Stations

1. Wires shall be brought to the surface and terminated in a CP test station.
2. Test Station shall not be located in traffic or pedestrian areas.
3. Provide a minimum of 48 inches of slack, coiled in each box.
4. Acceptable manufactures are:
 - a. NM-4, C.P. Test Services.
 - b. An approved equal.

END OF SECTION

02224-6
SECTION 02575

PAVEMENT REPAIR AND RESURFACING

PART 1 - GENERAL

1.1 DESCRIPTION

- A. This section addresses surface obstructions which the Contractor must remove and replace, such as pavement, drives, curbs, gutters, sidewalks, and similar surfaces, as required to perform the work.
- B. The words *Standard Street Specifications*, as used herein, refer to the current Design Criteria and Standards for Streets of the agency having jurisdiction.

PART 2 - MATERIALS

2.1 AGGREGATE, ASPHALT AND CONCRETE

- A. All materials and workmanship, such as but not limited to aggregate, bituminous material, and concrete, which are used in the repair of surface obstructions, shall conform to the specifications of the agency having jurisdiction. Contact the District for specifications if jurisdiction has not been established.

PART 3 - EXECUTION

3.1 MANHOLE RINGS

- A. Manhole rings shall be raised to the level of work in progress.
 - 1. Reference Section 02605, Subsection 3.1.

- B. All manhole rings and adjustment shims shall be straight, level, and properly aligned.
- C. All foreign matter shall be removed from the manholes immediately to provide free access to these facilities.

02575-1

3.2 ASPHALT AND CONCRETE, INCLUDING BASE AND GRAVEL SURFACING

- A. The Contractor shall remove, dispose of, and restore asphalt, concrete pavement, curbs, drives, sidewalks and gravel surfacing in accordance with the *Standard Street Specifications*.
 - 1. Contractor shall repair any damage to existing pavement, curbs, drives, or sidewalks which was caused by the work, as shown on the Construction Drawings directed by the District.
- B. Concrete drives, curbs, gutters, sidewalks, and similar structures shall be removed, disposed of, and restored in accordance with the agency having jurisdiction. The following minimum thickness shall apply if jurisdiction has not been established:
 - 1. Driveways and slabs shall be six (6) inches thick, or match the existing thickness (whichever is greater).
 - 2. Patios shall be four (4) inches thick, or match the existing thickness (whichever is greater).
 - 3. Gutters shall be six (6) inches thick, or match the existing thickness (whichever is greater).
 - 4. Concrete bases for brick pavers and concrete pavement shall be six (6) inches thick, or match the existing thickness (whichever is greater).
 - 5. Sidewalks shall be four (4) inches thick, or match the existing thickness (whichever is greater).
 - 6. Cross pans shall be eight (8) inches thick, or match the existing thickness (whichever is greater).
- C. Reference Section 03300.

3.3 FIELD QUALITY CONTROL

- A. Subgrade, aggregate base course, and bituminous pavement shall be compacted in accordance with the *Standard Street Specifications*.

02575-2

- B. Concrete

- 1. Reference the *Standard Street Specifications*.
- 2. Reference Section 03300.

END OF SECTION

02575-3
SECTION 02605

MANHOLES

PART 1 - GENERAL

1.1 DESCRIPTION

- A. This section addresses sanitary sewer manholes, and includes the acceptable products, materials, and practices which may be used in the construction and installation of manholes.
- B. Manholes shall be furnished with all accessories, including steps, base and cone sections, and ring and covers.
- C. Manholes shall be installed wherever there is a change in size, direction, slope, at junctions, at the end of each main, and at intervals of not more than 400 feet.
- D. All dead-end manholes, where a future sewer main extension is anticipated, shall be a precast base with no invert inlet penetration.

1.2 PRODUCT DELIVERY, STORAGE AND HANDLING

- A. Manholes shall be handled, stored, and protected in such a manner as to prevent damage to materials.
- B. All joint surfaces shall be free from dirt, oil, and grease at the time of installation.

PART 2 – PRODUCTS AND MATERIALS

2.1 PRECAST CONCRETE MANHOLES

- A. Precast manhole bases, risers and cone sections shall be manufactured in accordance with ASTM C478, and shall be made with Type I/II cement.
 - 1. All cone sections shall be the eccentric type.
- B. Concrete and Reinforcing Materials.
 - 1. All reinforcing materials shall conform to ASTM A615, A617, or ASTM A185.
 - 2. Reference Section 03400

02605-1

2.2 CAST-IN-PLACE MANHOLES

- A. Cement used in cast-in-place manholes shall conform to ASTM C150, Type I/II.
- B. All fine and course aggregate shall conform to ASTM C33.
- C. All deformed reinforcing bars shall conform to ASTM A615 or ASTM A617.
 - 1. All bars shall be either Grade 40 or 60
- D. All welded steel wire fabric shall conform to ASTM A185.
- E. Concrete used in cast-in-place manholes shall have a minimum of six (6) sacks per cubic yard, and shall develop a minimum compressive strength of 3500 psi after 28 days.
 - 1. Concrete shall have a maximum allowable water/cement ratio of 0.50, by weight.
 - 2. Concrete shall have a minimum 28-day compressive strength of 3000 psi.
- F. Reference Section 03300

2.3 MORTAR

- A. Mortar shall be Sand-Cement grout, using the following ratio of ingredients:
 - 1. One part Portland Cement; conforming to ASTM C150, Type I/II.
 - 2. Two parts sand; conforming to ASTM C144.
 - 3. 1/2 part hydrated lime; conforming to ASTM C207, Type S.

2.4 GROUT

A. Grout shall be one of the following:

1. Pre-mixed, non-shrink, non-metallic grout.

a. Or an approved equal.

2. Job-Mixed grout, using the following ration of ingredients:

02605-2

a. One part Portland Cement; conforming to ASTM C207, Type I/II.

b. One part sand; conforming to ASTM C144.

2.5 RING AND COVER

A. All ring and covers shall be cast iron material with a minimum of an H-20 load rating.

1. Acceptable manufacturers;

a. East Jordan Iron Works.

b. Or an approved equal.

2.6 STEPS

A. All steps, in manholes, shall be made of Copolymer Polypropylene Plastic conforming to ASTM C478 and ASTM C497.

B. All steps shall be spaced 12-inches apart, on center, and in uniform alignment.

C. The maximum distance from the cover of the manhole to the first step shall be 28-inches.

D. The maximum distance from the bench of the manhole to the lowest step shall be 18-inches.

2.7 PREFORMED PLASTIC GASKETS

A. All preformed plastic gaskets shall conform to AASHTO M198.

B. All manhole sections shall have two (2) preformed plastic gaskets per section

joint.

- C. Gaskets shall be pliable at the time of installation.

02605-3

2.8 PIPE PENETRATION GASKETS

- A. Acceptable gaskets and their manufacturers are:
 - 1. “A-LOK”; A-LOK Products, Inc.
 - 2. “PSX”; PRESS-SEAL Gasket Corporation.
 - 3. Or an approved equal.

PART 3 - EXECUTION

3.1 INSTALLATION

- A. Trenching, backfilling, and compaction.
 - 1. Reference Section 02221.
- B. Connections to Existing Manholes
 - 1. Connections to existing manholes shall be made by core-drilling unless otherwise indicated.
- C. Manhole Construction
 - 1. Standard manholes shall be installed in accordance with the “Standard Manhole” detail in the appendix.
 - 2. Outside drop manholes shall be installed in accordance with the “Standard Outside Drop Manhole” detail in the appendix.
 - a. Outside drop manholes are required whenever the difference between invert elevations is two (2) feet or greater.

3. Flat-top manholes shall be installed in accordance with the “Standard Flat-Top Manhole” detail in the appendix.
 - a. Flat-Top manholes are required whenever the distance between the finished road surface and a manhole barrel section does not allow room for a cone section.
 - b. Access holes for flat-top manholes shall be offset from center.
 - i. If the distance from the manhole cover to the invert of the sewer main is less than three (3) feet, the access hole shall be centered.
4. Manholes shall be constructed at the location and to the elevation indicated on the approved Construction Drawings, or as stated by the District to accommodate field conditions.
 - a. The location of manholes shall be referenced by the Design Engineer, to a minimum of two permanent surface references, and recorded on the Record Drawings.
5. The manhole shall be set plumb.
 - a. Precast concrete adjustment rings shall be used to bring the ring and cover to grade.
 - i. The total height from the top of the cone section to the finish street grade shall not exceed sixteen (16) inches.
 - ii. The adjustment rings shall be flush with the inside of the manhole.
6. Manhole sections shall be joined to each other and to the base using a double row of preformed plastic gaskets.
 - a. All joint surfaces shall be kept clean and dry during installation.
 - b. The joint between the manhole section and the cast-in-place base shall be grouted on the inside to provide a smooth surface.
7. Concrete adjustment shims and ring and covers shall have a preformed plastic gasket between each component on all off site manholes.
8. All lifting holes, joints, and other imperfections shall be filled only upon request by the District, using an approved product.

02605-4

9. The exterior surfaces of manholes shall have a 1/16 inch coating of tar if ground water is present.

END OF SECTION

02605-5

SECTION 02622

PLASTIC GRAVITY SEWER PIPE

PART 1 - GENERAL

1.1 DESCRIPTION

- A. This section addresses plastic gravity sewer pipe and includes the acceptable materials and construction practices which may be used in the installation of plastic gravity sewer pipe.
 1. All pipe shall be furnished complete with all fittings and accessories.

1.2 PRODUCT DELIVERY, STORAGE AND HANDLING

- A. Handling.
 1. Pipe shall not be handled in a manner which will cause damage to the pipe.
 2. Pipe or fittings shall not be dropped.
 3. Care must be taken to prevent damage to the pipe and fittings by impact, bending, compression, or abrasion.
 4. Damaged pipe or fittings shall not be installed.
- B. Storage.
 1. Lubricant shall not be stored or handled in a manner which will cause contamination to the lubricant.

2. Rubber gaskets shall be stored in a location which protects them from deterioration.
3. Pipe shall be stored in accordance with the manufacturer's specifications.
4. Pipe shall be stored on a surface which provides even support for the pipe barrel.
 - a. Pipe shall not be stored in such a way as to be supported by the bell.
 - b. Pipe which has a longitudinal deflection greater than 1/8 inch per foot shall not be used.
5. Pipe which exhibits any signs of ultraviolet degradation shall not be used.

02622-1

PART 2 - PRODUCTS

2.1 PLASTIC GRAVITY SEWER PIPE

- A. All plastic gravity sewer pipe and all fittings shall be made from PVC components which conform to ASTM D1784.
- B. All plastic gravity sewer pipe and all fittings shall be manufactured in accordance with ASTM D3034.
 1. The standard dimension ratio (SDR) of plastic gravity sewer pipe shall not exceed 35 unless required by the District.

2.2 JOINTS

- A. All joints shall be of the push-on bell and spigot type, and shall be manufactured in accordance with ASTM D3212.
 1. All gaskets shall be manufactured in accordance with ASTM F477.
 2. All bells shall be formed integrally with the pipe and shall contain a factory installed elastomeric gasket, which is positively retained.
 3. Lubricant shall be that which is specified by the pipe manufacturer.

PART 3 - EXECUTION

3.1 INSTALLATION

- A. Reference Section 02722, Subsection 3.3.

END OF SECTION

02622-2
SECTION 02722

SANITARY SEWER COLLECTION SYSTEM

PART 1 - GENERAL

1.1 DESCRIPTION

- A. This section addresses the acceptable products, materials, and construction practices which may be used in the installation of sanitary sewer collection systems.
- B. The minimum allowable pipe diameter of sanitary sewer mains shall be 8-inches.

1.2 QUALITY ASSURANCE

- A. Construction Staking.
 - 1. Reference Section 02221, Subsection 1.2.
- B. Horizontal alignment shall remain uniform between consecutive manholes as designed on the Construction Drawings.
- C. Vertical alignment shall remain uniform between manholes, with no deviation from the grade specified on the Construction Drawings.

1.3 PRODUCT DELIVERY, STORAGE AND HANDLING

- A. Reference Sections 02605 and 02622.

1.4 JOB CONDITIONS

A. Foreign material (debris, tools, clothing, or other material), including trench water, shall not be permitted to enter the pipe under construction.

1. The portion of the pipe being installed shall not be used to dewater the trench.

B. Water shall be prevented from entering sewer pipe which is already in service and has been accepted by the District.

C. Effective measures shall be used to prevent uplifting or floating of the pipeline prior to completion of the backfilling operations. Dewatering methods and procedures shall be the responsibility of the Installation Contractor.

02722-1

D. Pipe shall not be installed under the following conditions:

1. When the trench contains water.

2. When weather conditions are unsuitable.

a. Temperature is less than 0 degrees Fahrenheit.

3. When the trench bottom is unstable.

E. Pipe and appurtenances shall be protected against dropping and damage.

1. Pipe and appurtenances shall not be used if they are damaged.

PART 2 - PRODUCTS

2.1 MANHOLES

A. Reference Section 02605.

2.2 PLASTIC GRAVITY SEWER PIPE

A. Reference Section 02622.

PART 3 - EXECUTION

3.1 INSPECTION

A. Pipe, fittings, and manholes, shall be free of dirt or other objects prior to installation.

B. Pipe and fittings shall be inspected for cracks, dents, abrasions or other flaws prior to installation.

1. Defective pipe and fittings shall be marked and remain on the site until removal is approved by the District.

C. Manholes shall be inspected for cracks or other flaws prior to installation.

1. Damaged manholes shall be marked and remain on the site until removal is approved by the District.

3.2 PREPARATION

A. Trenching, backfilling, and compacting.

02722-2

1. Reference Section 02221.

B. Cutting the pipe.

1. The pipe shall be cut smooth, straight, and at right angles to the pipe axis, with saws or pipe cutters which are designed specifically for the material.
2. The cut end of the pipe shall be beveled in accordance with the manufacturer's recommendations.
3. Burrs shall be removed and all dust shall be wiped off of the jointing surface.

C. Connections

1. The location and elevation of the existing pipes and manhole inverts shall be verified prior to construction.
2. Connections to existing pipes shall be made with an approved coupling device.

D. Joints

1. Dirt, oil grit, and other foreign matter shall be removed from the inside of the bell and the outside of the spigot.
2. The lubricated joint surfaces shall be kept clean in accordance with manufacturer's recommendation.
3. The pipe shall have a depth mark prior to assembly to insure that the spigot end is inserted the full depth of the bell end joint.
4. Stabbing of the pipe shall not be allowed.

5. Previously completed joints shall not be disturbed during the jointing operation.
6. After the initial acceptance of the sewer main, the Contractor shall be responsible for the repair of any leak, resulting from improper workmanship or materials, which is discovered within a one (1) year period.

3.3 PIPE INSTALLATION

- A. Pipe installation shall begin at the lowest elevation and proceed upstream to the highest unless prior approval is obtained from the District.

02722-3

1. Pipe shall be installed so that the bells are pointing uphill.
 2. The pipeline shall be installed so that a uniform grade is maintained between manholes.
- B. The joint shall be completed in accordance with the pipe material specification, and the pipe shall be adjusted to the correct line and grade as each length of pipe is placed in the trench.
 1. Pipe shall be laid to and maintained at required lines and grades as specified in the approved construction drawings.
 - C. The pipe shall be secured in place with the specified granular bedding material consolidated under and around the pipe.
 - D. The Contractor shall prevent the opening of joints during bedding and backfilling operations.
 1. Bedding material shall not be dropped onto unsupported pipe, which has been set to alignment and grade.
 - E. Concrete encasements shall be provided when indicated on the Construction Drawings or by specific approval of the District.
 1. Cast-In-Place Concrete.
 - b. Reference Section 03300.
 2. In any instance where a water main crosses a sewer line, and the sewer is above the water main, or the vertical distance between the two mains is less than eighteen (18) inches, the crossing shall be constructed by one of the following methods:

a. One length of sewer pipe, with a length of thirteen (13) feet or greater, shall be installed.

i. The sewer pipe shall be centered on the water main.

3. Sanitary sewer mains which cross waterways shall be installed as indicated on the approved construction drawings or as required by the District.

3.4 MANHOLE INSTALLATION

A. Reference Section 02605.

02722-4

B. Manholes shall be installed at the location and to the elevation shown on the Construction Drawings, or as approved by the District.

C. Measurements of the location and elevation of sewer main inverts shall be surveyed for Record Drawings, stamped and approved by the Design Engineer.

3.5 SERVICE CONNECTIONS

A. Service wyes, tees, or saddles shall be installed at the locations designated on the approved construction drawings.

1. Reference the “Standard Sewer Service Connection” detail in the appendix.

2. The centerline of the service branch shall be inclined upward at a 45 degree angle.

B. Service connections on existing mains shall be installed using a saddle or insert-a-tee.

C. All sewer services shall be extended at a constant grade to a point six (6) feet inside the property line.

1. Maximum grade of all sewer services shall be eight (8) percent.

2. Minimum grade of four (4) inch sewer services shall be ¼ inch per foot, (a 2% grade).

3. Minimum grade of six (6) inch sewer services shall be 1/8 inch per foot, (a 1% grade).

D. The end of all sewer services shall be plugged with an airtight plug.

E. The end of all sewer services shall be marked with a 4” x 4” wooden marker.

1. All wooden markers shall extend from the end of the service to a point two (2) feet above the ground surface.
- F. The Contractor shall mark the location of the sewer service with a scored “S”, four (4) inches high, into the face of the top of curb or gutter.

END OF SECTION

02722-5

SECTION 03300

CAST-IN-PLACE CONCRETE

PART 1 - GENERAL

1.1 DESCRIPTION

- A. This section covers cast-in-place concrete for manholes, encasement, and cut-off walls, including forms, reinforcing steel, finishing and curing, and other appurtenant work.
1. Reference Section 02605 and Section 02722

PART 2 - MATERIALS

2.1 CEMENT

- A. All cement shall be Portland Cement.
1. Portland Cement shall conform to ASTM C150.
 2. Portland Cement shall be Type I/II.
 - a. No other cement shall be used without the prior permission of the District.

2.2 AGGREGATES

- A. All fine and course aggregate shall conform to ASTM C33.

2.3 WATER

- A. All water shall be free from objectionable quantities of silt, organic matter, alkali, salts, and other impurities or conform to ASTM C94.

2.4 ADMIXTURES

- A. An air-entraining agent shall be used in all concrete.
 - 1. All air-entraining agents shall conform to ASTM C260.
 - 2. Total air content of 5 to 8 percent shall be provided.

- B.

03300-1

A water-reducing admixture may be used, if approved by the District
 - 1. A water-reducing admixture shall conform to ASTM C494, for Type A or Type D chemical admixture.
 - 2. The water-reducing admixture shall not contain any calcium chloride.
 - 3. The water-reducing admixture shall be compatible with the cement being used.
- C. Accelerators
 - 1. Accelerators shall conform to ASTM C494 and ACI 306.
 - a. If calcium chloride is used as an accelerator, the amount used should not exceed 2%, by weight, of the cementitious material.
 - b. Calcium chloride shall be in solution prior to adding it to the batch process.
- D. Fly-Ash
 - 1. When fly-ash is used in concrete, the cement replacement shall not exceed 20%.
 - a. Class C or Class F fly-ash shall conform to ASTM C618.
 - b. Class C fly ash will not be permitted where sulfate resistant concrete is required.
- E. Any admixtures except air entraining agents, accelerators, and retarders must be approved by the District.

2.5 CONCRETE REINFORCEMENT

- A. All deformed reinforcing bars shall conform to ASTM A615 or ASTM A617.
 - 1. All bars shall be either Grade 40 or 60.
- B. All welded steel wire fabric shall conform to ASTM A185.

03300-2

PART 3 - CONCRETE

3.1 GENERAL

- A. Concrete shall have a minimum of 6 sacks per cubic yard, and shall develop a minimum compressive strength of 3,500 psi after 28 days.
- B. Concrete shall have a maximum allowable water/cement ratio of 0.50, by weight.
 - 1. The water cement ratio may be increased to 0.56, by weight, if a water-reducing agent is used.
 - a. High early or rapid set concrete will be allowed in high traffic situations.
 - b. Reference paragraph 2.4 - B, in this section.

3.2 PLACING

- A. Unless prior written permission is obtained from the District, concrete shall not be placed unless the air temperature adjacent to the concrete placement is 30 degrees Fahrenheit, and rising.
 - 1. If the temperature drops below 40 degrees Fahrenheit, concrete placement shall cease.
 - 2. The temperature of the mix shall not be less than 50 degrees Fahrenheit, nor more than 90 degrees Fahrenheit at the time of the placement.
 - 3. If heated mixing water and/or an accelerator is used, the above temperature restrictions may be waived with prior written permission by the District.

- a. Water shall not be heated to a temperature exceeding 150 degrees Fahrenheit.
- B. Unless prior permission is obtained from the District, concrete shall not be placed unless the temperature of the plastic concrete cannot be maintained at 90 degrees Fahrenheit or lower.
 - 1. To facilitate the placement of concrete in hot weather, the aggregate or the water may be cooled.

03300-3

3.3 FINISHING

- A. Manhole bases and inverts shall be true to line and grade with a smooth invert and a broom finish on the invert benches.

3.4 CURING

- A. Finished concrete shall be cured by protecting it against moisture loss, rapid temperature change, and from rain, flowing water and mechanical injury for a minimum of 72-hours after placement.
 - 1. Concrete shall be maintained at a minimum temperature of 50 degrees Fahrenheit during the curing period.
 - 2. The Contractor is responsible for protecting the concrete from traffic and the elements.

END OF SECTION

03300-4
SECTION 03400

PRECAST CONCRETE

PART 1 - GENERAL

1.1 DESCRIPTION

- A. This section addresses precast concrete products.
- B. Reference Sections 02605

1.2 PRODUCT DELIVERY, STORAGE AND HANDLING

- A. All precast concrete parts shall be handled, stored, and protected in a manner which will prevent damage to materials.

PART 2 - PRODUCTS

2.1 PRECAST CONCRETE PRODUCTS

- A. Barrels, cone sections and flat slab tops of manholes shall conform to and be designated as ASTM C478, and shall be made with Type I/II Cement.
 - 1. Unless written permission is obtained from the District, concentric cone sections will not be allowed.
- B. Concrete and Reinforcing Materials.
 - 1. Reference Section 03300.

2. Minimum reinforcement for bases of manholes shall consist of welded wire fabric, 4 x 4 – W4 x W4.
 - a. Reference ASTM C478.

END OF SECTION

03400-1
Appendix

Trench and Bedding Typical

Typical Pipe Casing

Typical Manhole

Typical Out-Side Drop Manhole

Typical Flat-Top Manhole

Typical Sanitary Sewer Service Connection

Typical Groundwater Barrier

Typical Utility Service Location

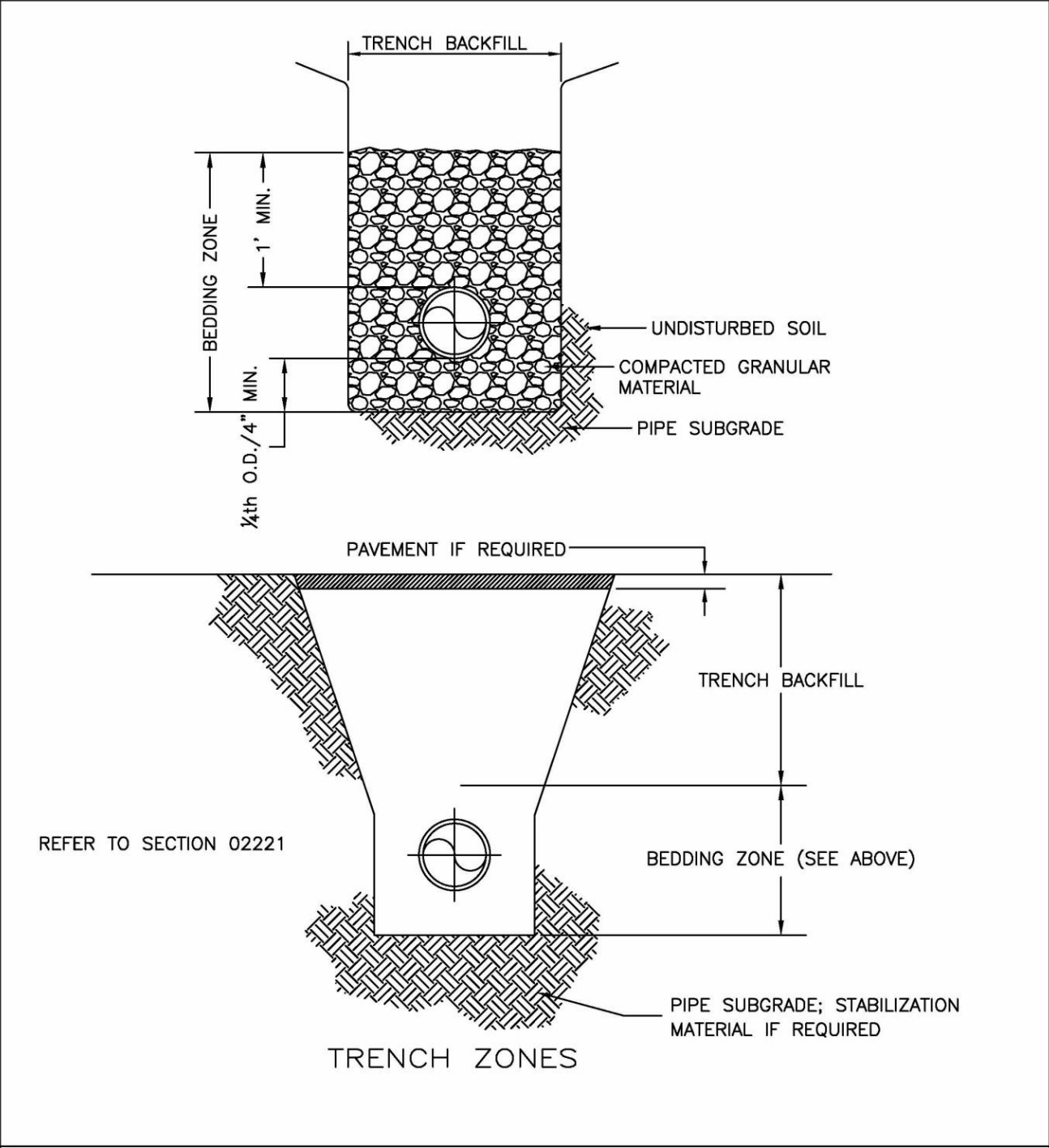

TRENCH AND BEDDING TYPICAL

	SOUTH FORT COLLINS SANITATION DISTRICT Office (970) 226-3104 Fax (970) 226-0186	APPROVED:	SCALE: NTS
		DATE: 12-15-2010	

ANODE LEADS	BLACK
PIPELINE TEST WIRES	RED FOR STEEL BLUE FOR DI
CASINGS	ORANGE
REF ELECTRODE	YELLOW
TRACER WIRE	WHITE

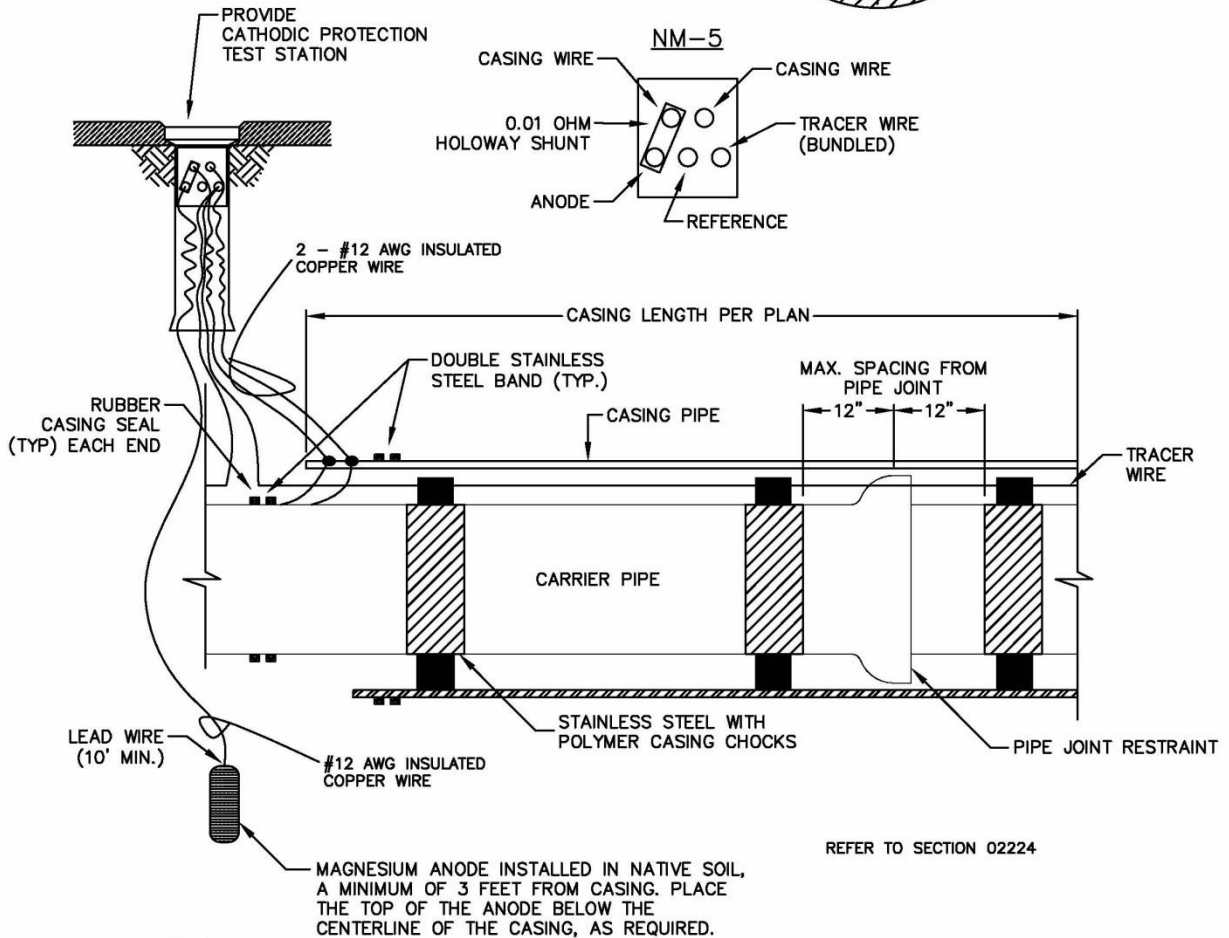
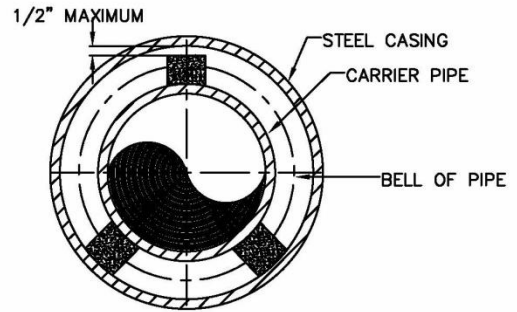

NOTES:

1. EACH BARREL SECTION OF PIPE WITHIN THE CASING SHALL HAVE A MINIMUM OF (3) CASING CHOCKS. THE MIDDLE CHOCK SHALL BE CENTERED BETWEEN EACH PIPE JOINT.

TYPICAL PIPE CASING



SOUTH FORT COLLINS SANITATION DISTRICT
Office (970) 226-3104 Fax (970) 226-0186

APPROVED:

DATE: 2-22-2012

SCALE: NTS

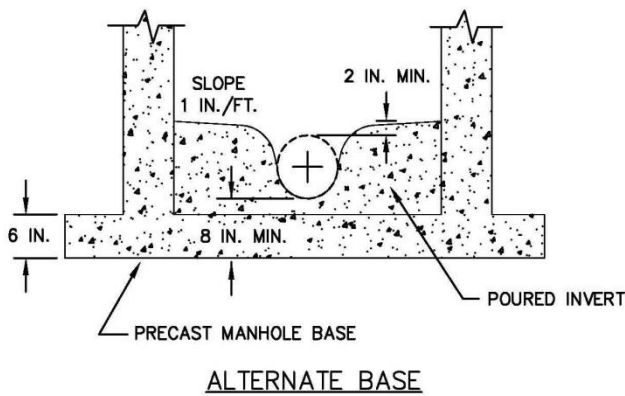
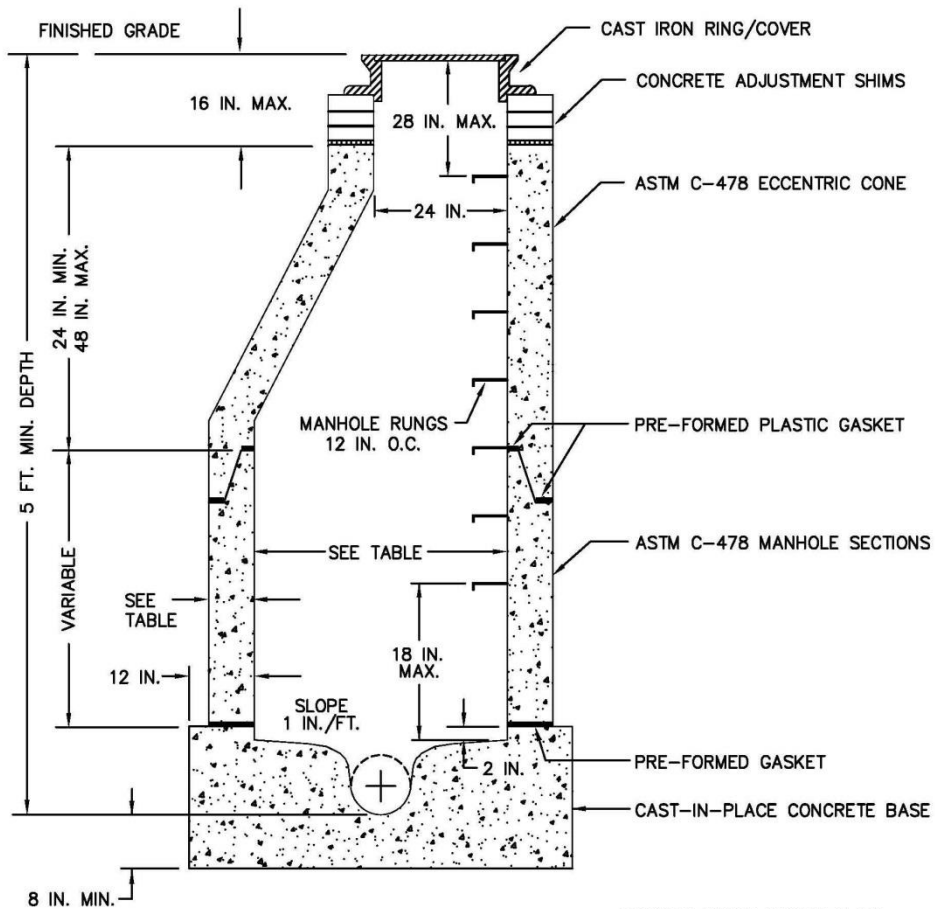

MINIMUM INSIDE DIAMETER OF MANHOLE SHALL BE AS FOLLOWS:

PIPE SIZE	MIN. MANHOLE DIAMETER
15 IN. OR LESS	48 IN.
18 IN. TO 30 IN.	60 IN.
OVER 30 INCHES	72 IN.

MANHOLE WALL THICKNESS			
I.D.	48Ø	60Ø	72Ø
	5 IN.	6 IN.	7 IN.

TYPICAL MANHOLE



SOUTH FORT COLLINS SANITATION DISTRICT
OFFICE (970) 226-3104 FAX (970) 226-0186

APPROVED:

DATE: 1-29-2014

SCALE: NTS

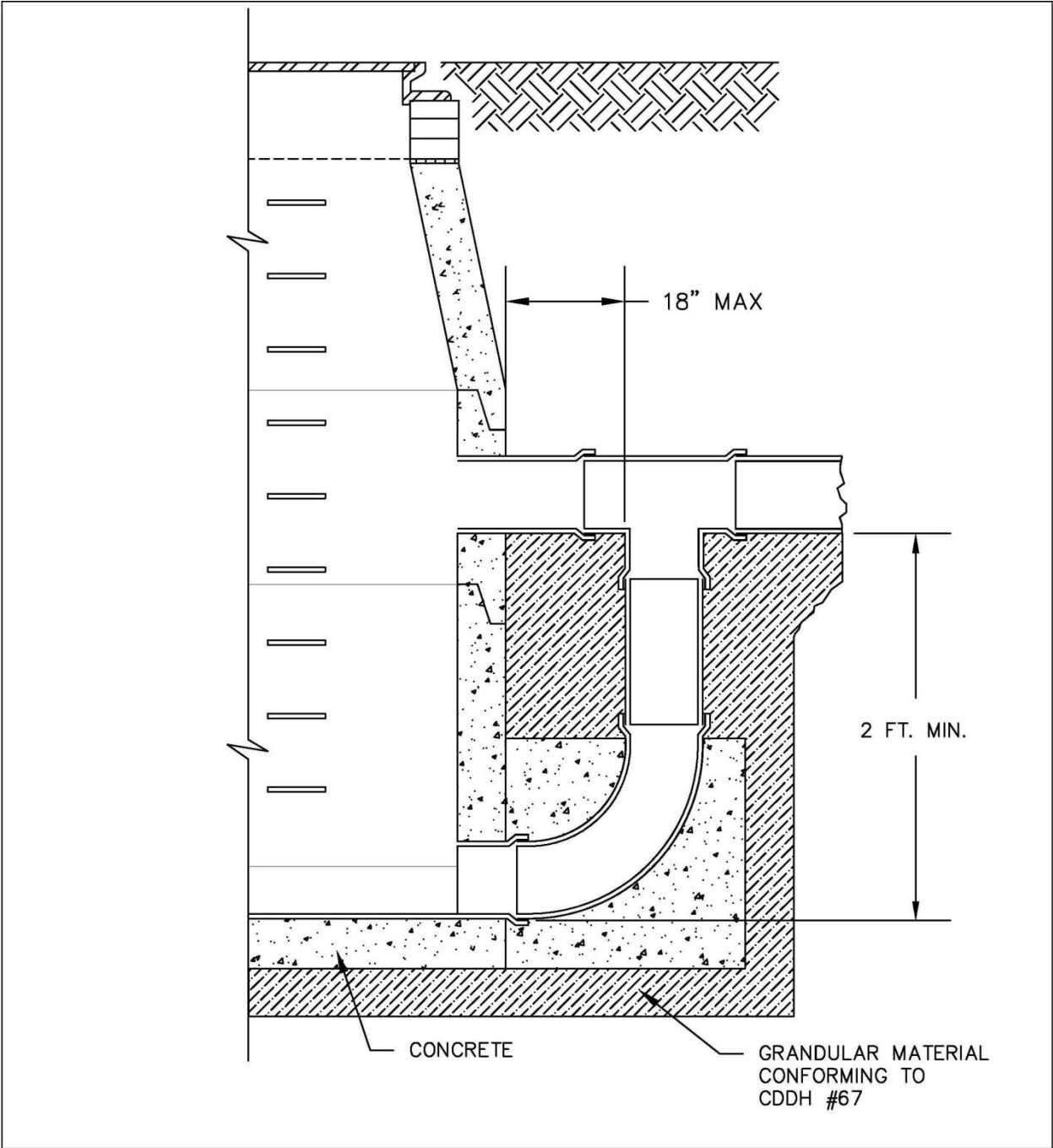

TYPICAL OUTSIDE-DROP MANHOLE



SOUTH FORT COLLINS SANITATION DISTRICT
 OFFICE (970) 226-3104 FAX (970) 226-0186

APPROVED:
 DATE: 7-15-2014

SCALE: NTS

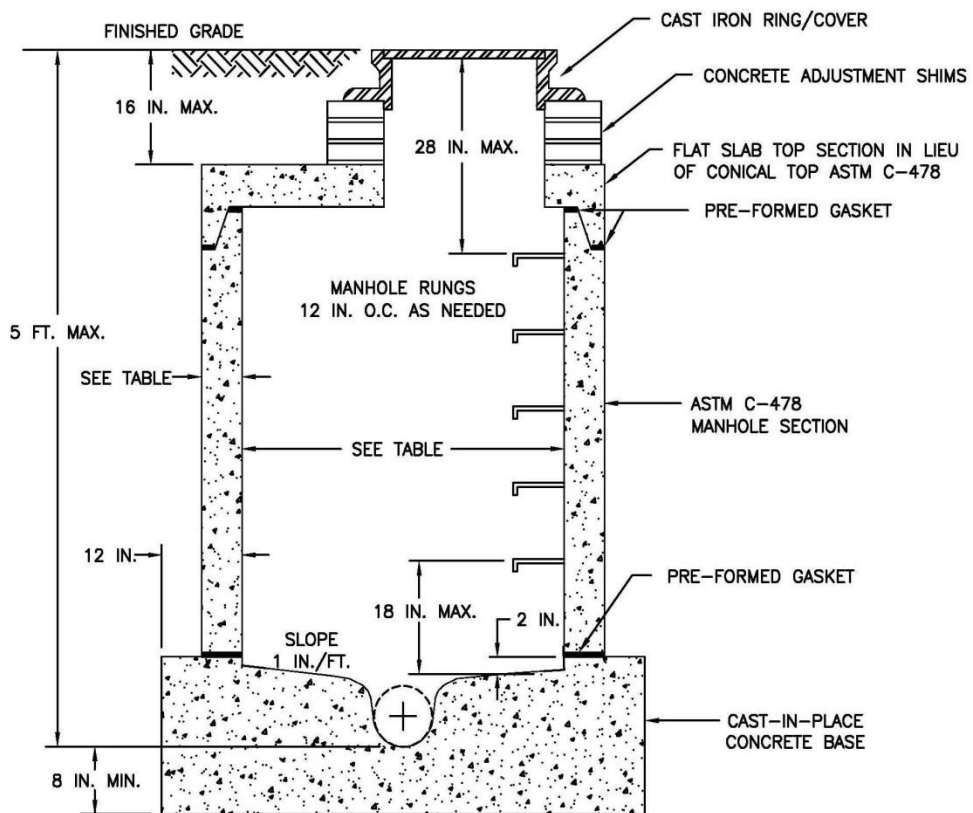

NOTE: IF MANHOLE DEPTH IS LESS THAN 3 FEET, TOP SECTION SHALL HAVE A CONCENTRIC OPENING.

MINIMUM INSIDE DIAMETER OF MANHOLE SHALL BE AS FOLLOWS:

PIPE SIZE	MIN. MANHOLE DIAMETER
15 IN. OR LESS	48 IN.
18 IN. TO 30 IN.	60 IN.
OVER 30 INCHES	72 IN.

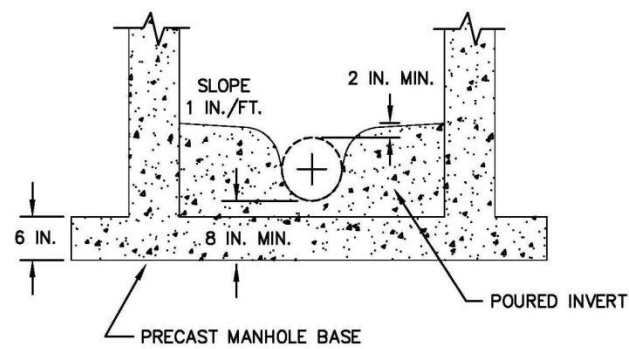

ALTERNATE BASE

MANHOLE WALL THICKNESS			
I.D.	48ø	60ø	72ø
	5 IN.	6 IN.	7 IN.

TYPICAL FLAT-TOP MANHOLE



SOUTH FORT COLLINS SANITATION DISTRICT
 OFFICE (970) 226-3104 FAX (970) 226-0186

APPROVED:
 DATE: 1-29-2014

SCALE: NTS

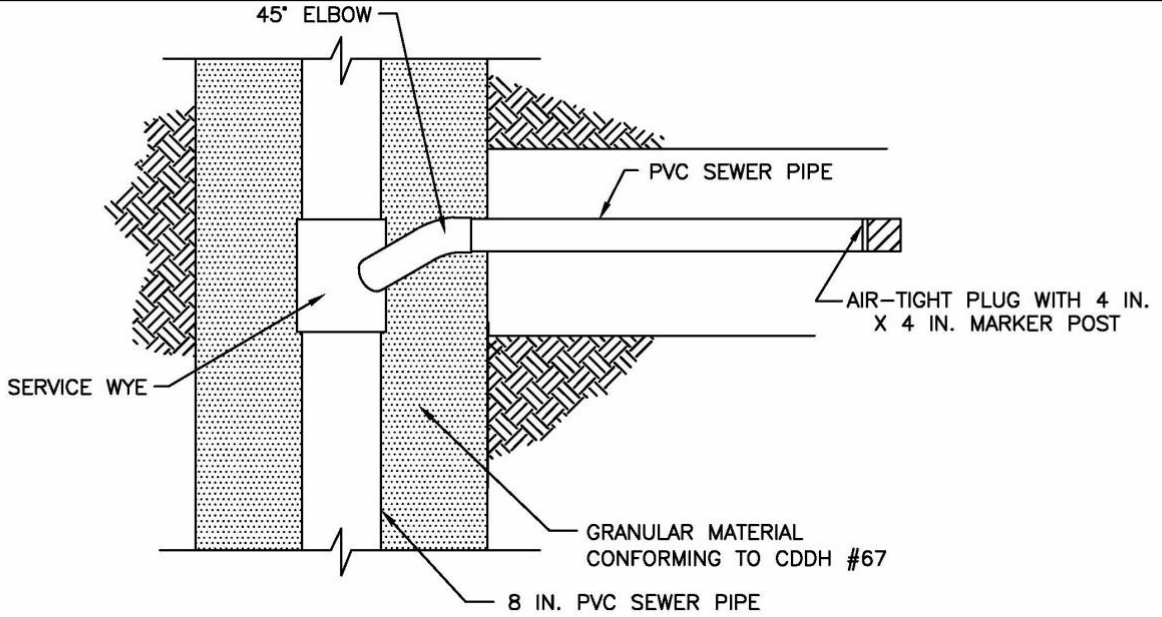

PLAN VIEW

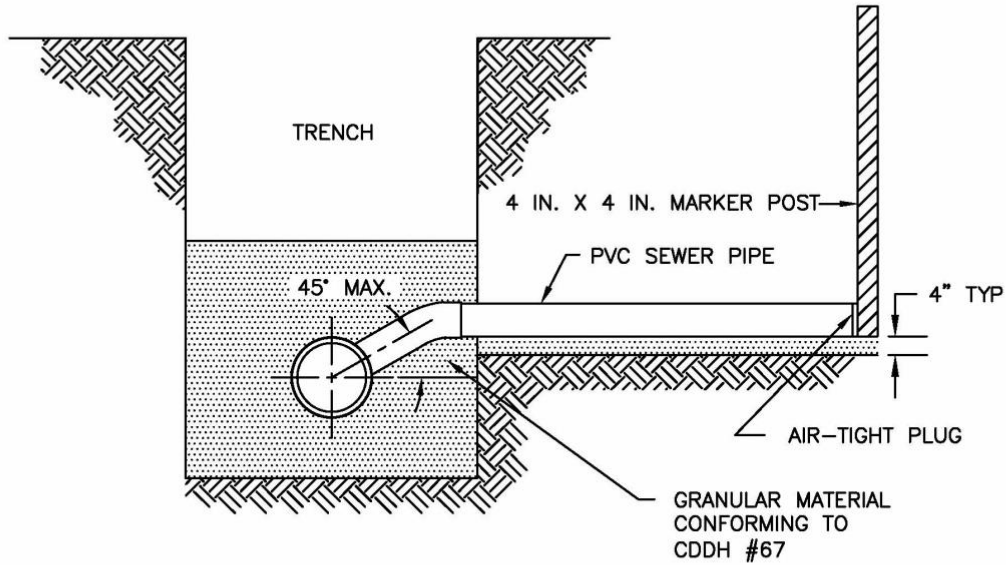

CROSS SECTION

NOTE: WYE CONNECTION NOT ALLOWED ON VCP

TYPICAL SANITARY SEWER SERVICE CONNECTION



SOUTH FORT COLLINS SANITATION DISTRICT
Office (970) 226-3104 Fax (970) 226-0186

APPROVED:

DATE: 12-15-2010

SCALE: NTS

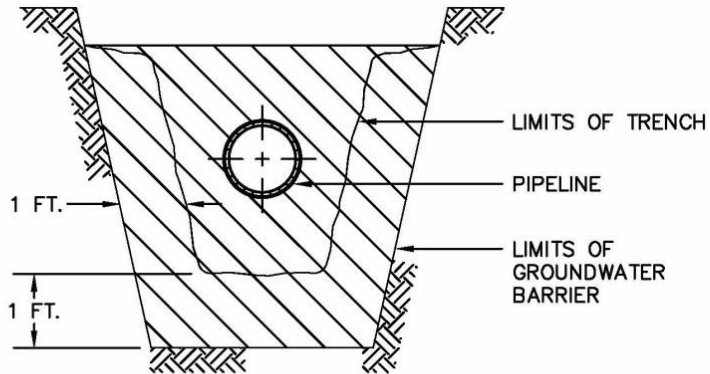
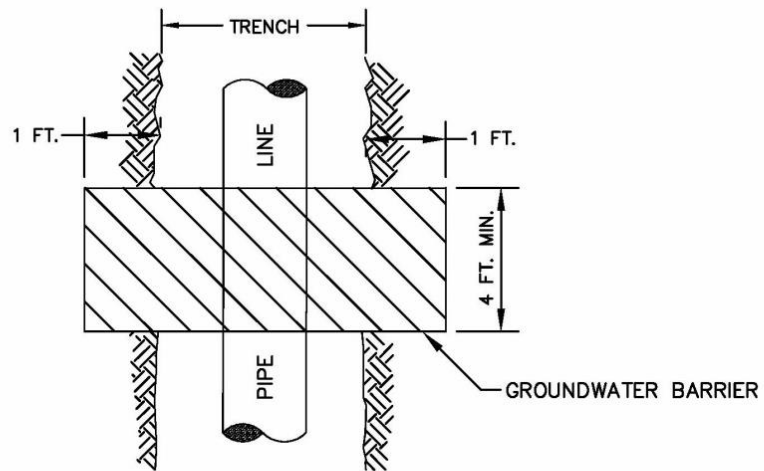

NOTES:

1. WALL EXTENDS A MINIMUM OF 12" INTO UNDISTURBED SOIL ON EACH SIDE AND ON BOTTOM OF TRENCH.
2. SPACE GROUNDWATER BARRIERS A MAXIMUM OF 400 FEET APART. BARRIERS ARE TYPICALLY LOCATED UPSTREAM OF MANHOLES.
3. THE GROUNDWATER BARRIER SHALL EXTEND TO A POINT TWO FEET ABOVE THE GROUNDWATER LEVEL AS SHOWN IN THE APPROVED PROJECT GEOTECHNICAL INVESTIGATION REPORT.
4. REFER TO SECTION 02221.

TYPICAL GROUNDWATER BARRIER



SOUTH FORT COLLINS SANITATION DISTRICT
Office (970) 226-3104 Fax (970) 226-0186

APPROVED:

DATE:

12-15-2010

SCALE: NTS

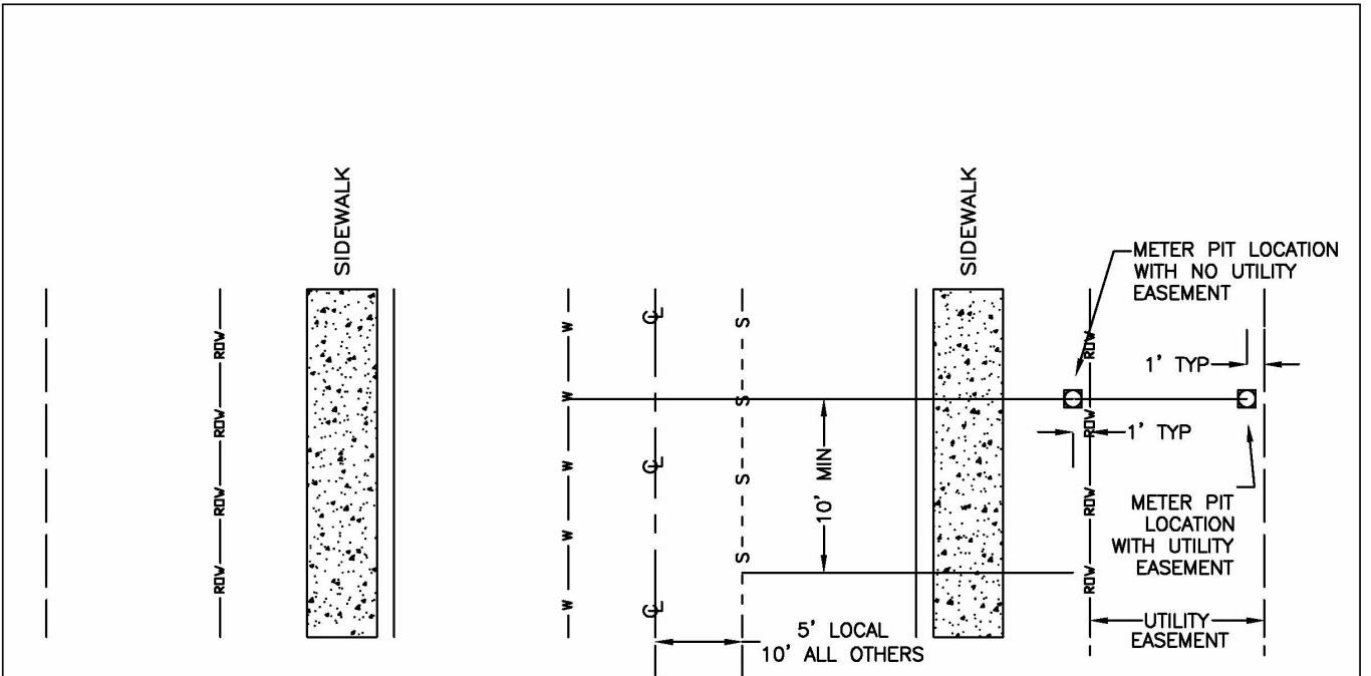

PLAN

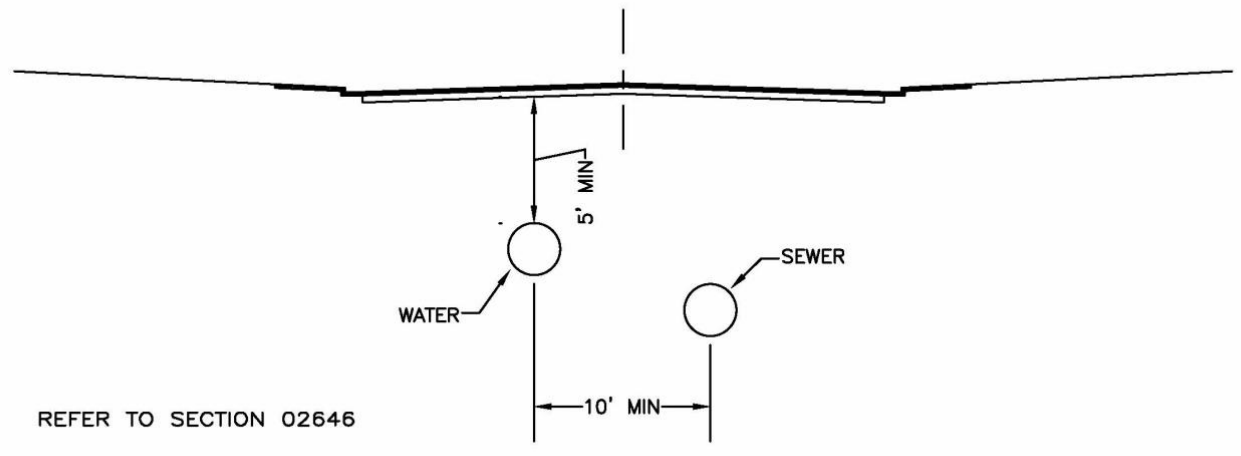

REFER TO SECTION 02646

SECTION

TYPICAL UTILILTY SERVICE LOCATION

	<p>SOUTH FORT COLLINS SANITATION DISTRICT Office (970) 226-3104 Fax (970) 226-0186</p>	APPROVED:	SCALE: NTS
		DATE: 12-15-2010	