

SAFETY RULES

1. **Never** mount any tower system close to wires or power lines. Stay **at least** 1½ times the overall height away from any power lines or wires.
2. **Never** attempt to touch someone who is in contact with power lines or wires.
3. **Never** climb the tower. Serious injury could result from a fall. This is even more dangerous when you are on a roof top.
4. If you drop something while working on a roof, **never** try to catch or stop it. Let it fall and keep your own balance secure.
5. Use the buddy system. **Always** have someone helping nearby.
6. **Always** keep children away.
7. **NEVER** attempt to install or attempt to repair equipment while under the influence of drugs, alcohol or any medication.

Please keep these instructions in a safe place after installation.

GlenMartin WARRANTY

GlenMartin, Inc. warrants this M-13 tower package for one full year. If this product fails to give the original purchaser complete satisfaction within one year from the original date of purchase, return it to the nearest authorized distributor and GlenMartin, Inc. will repair it, free of charge. GlenMartin, Inc. will not be liable for loss or damage to property or any incidental or consequential loss or expense from property damage due directly or indirectly from the use of this product.



GlenMartin, Inc.
13620 Old Hwy 40
Boonville, Missouri 65233 USA

PHONE (800) 486-1223
<http://www.glenmartin.com>

M-1330A, 40A, 50A Tower Packages

DATE PURCHASED:

OWNER'S MANUAL

CONTENTS	PAGE #
Packing List	2
Footing Assembly	3
HingeBase Specs	4
Hazer Operation	5
Tower Grounding	6
Hazer Parts Diagram	7
Guy Wire System	8
Accessories	9
Guy & Wind Information	10
Safety Rules	12
GME Warranty	12



CONGRATULATIONS!

We would like to thank you for choosing a GlenMartin, Inc. **M-1330A, M-1340A, or M-1350A** Tower with the H5 Hazer . This premium tower is manufactured in the United States of quality 6061-T6 anodized aluminum, stainless steel and galvanized steel for durability and long life. With proper care, your tower and Hazer should give you a lifetime of use.

TOOLS YOU'LL NEED FOR ASSEMBLY AND INSTALLATION



SOCKET SET



**ADJUSTABLE
END WRENCH**

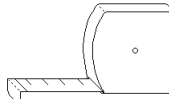

TAPE MEASURE

READ CAREFULLY - THEN PLAN YOUR INSTALLATION PROCEDURE CAREFULLY

Locate your tower site. Maintain a safe distance from all power lines. At least one and one-half to twice the height of the tower and antenna is a safe distance. Remember that any contact with power lines can be fatal to you! All towers should be properly guyed. All tower installations should be grounded per local or national codes. All towers should be installed by trained and experienced personnel and should be inspected by qualified personnel at least twice a year.

1. Verify that your packing slip is correct and that you have received what was ordered and that it is in good condition. The following is essentially what is included in an M-1350A or M-1330A tower package:

- 1 CHB-13 concrete footing box
- 1 tower section with hinged base and winch plate attached
- 1 tower section with top pulley bracket and Hazer 5
- 1, 2 or 3 intermediate tower sections
- 1 GR-5080 eight foot ground rod
- 3 ES-60 6" helix dia. x 48" long earth screws

- 1 carton containing the following items**
- 3 GW-1318 guy wire brackets mounted on tower
- 3 TB-3806 3/8 x 6" turnbuckle
- 3 RG-4010 link from turnbuckle to earth screw
- 125', 165 or 210' 5/32" Stainless Steel Wire Rope
- 3 thimbles for guy (6 on GW-1318, 6 pkg. separately)
- 24 3/16" U-bolt Clip
- 2 GR-4400 ground rod clamp
- 4 feet of #4 ground cable
- 1 ground rod lug for tower hinge base
- 1, 2, 3 or 4 sets of connecting braces and bolts for tower joints

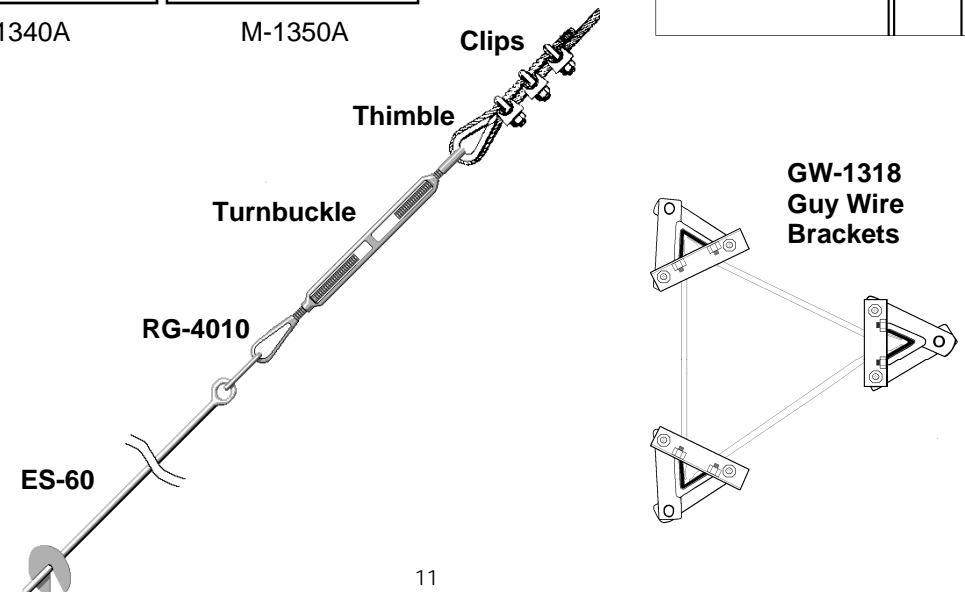
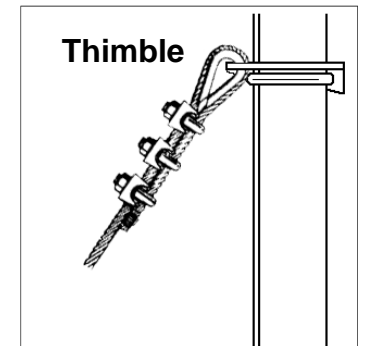
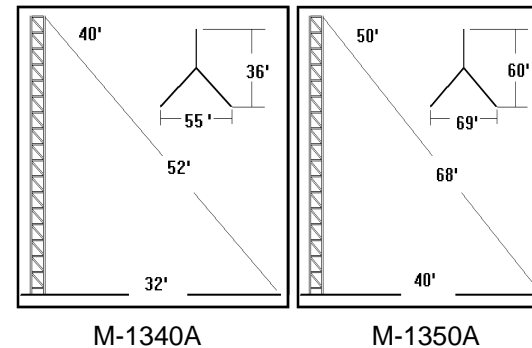
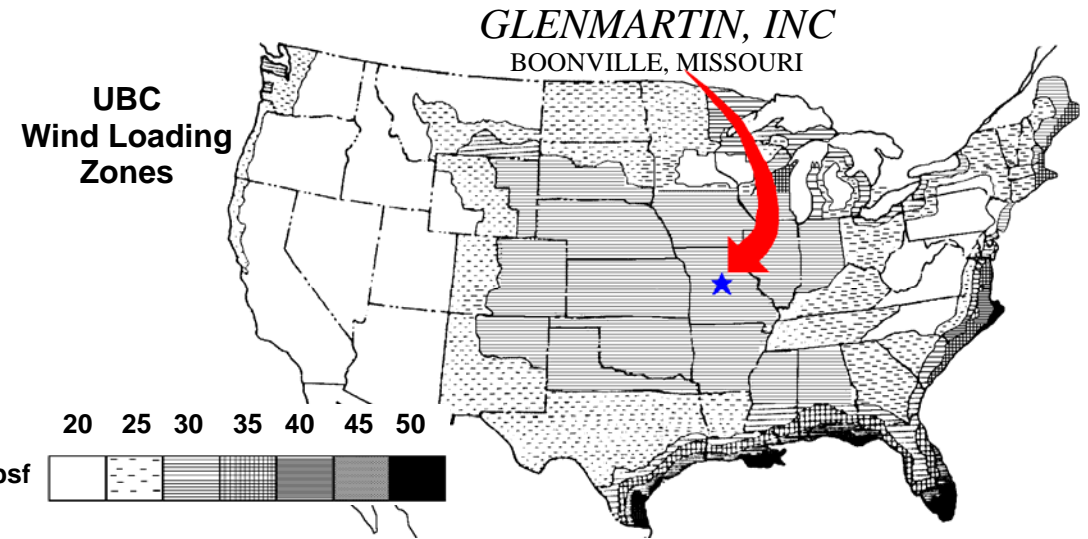

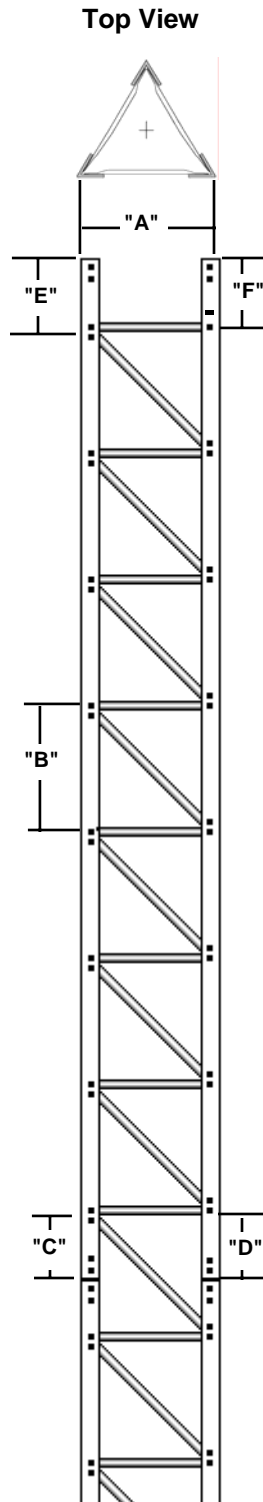

M-1330A/ 40A/ 50A		
	CHB-13	M-1330A/ 40A/ 50A
"A" (Inches)	45"	12-3/4
"B" (Inches)	33"	15
"C" (Inches)		5-1/2
"D" (Inches)	36.5"	7-1/2
"E" (Inches)		9-1/2
"F" (Inches)		7-1/2
Cubic Yards of Concrete:	1.04	
Centerline of Bolts (Inches):	10.75	
Length of Sections (Inches):	120	
Material:	Anodized Aluminum 6061-T6	
Siderail Dimensions (Inches):	0.19 x 1.5 x 1.5	
Weight Per Section (lbs.)	33	
Brace Dimensions	1/2 O.D. x .062 Wall	
Hardware:	18-8 Stainless Steel 1/4-20 X 3/4	
Total projected area of one face per foot equals .165 square feet.		
Maximum allowable vertical load on one leg equals 8750 pounds.		

Tower Wind Load Capacity With Guys at Top					
miles per hour		80 mph	87 mph	100 mph	112 mph
lbs. per sq. feet		25 psf	30 psf	40 psf	50 psf
total area	M-1330A	16.8	14	10.5	8.4
in sq. feet	M-1340A	15.6	13	9.75	7.8
	M-1350A	14.4	12	9	7.2

NOTES:

1. It may be necessary to secure the services of a local engineer to determine that installation complies with local building codes.
2. All tower installation should be grounded in accordance with local or national codes.

2. CONCRETE FOOTING SECTION - CH-13: Dig appropriate size hole (see chart on Pg. 4). Some customers ave had success renting a one or two man post hole digger to do the hard work. A hole is drilled in each corner and along the edges, then as many as possible in the center. The loose dirt can be shoveled out fairly easy. It is recommended that concrete be poured against undisturbed soil if at all possible. A two by four frame is sometimes constructed as a form on top of the ground to screed the concrete to. This form should be leveled and staked in place. Next, bolt the CHB-13 together. Try the hinged base (HB-13) over three studs of the CHB-13. The CHB-13 is set in the hole and can be secured in place by driving a rebar at each corner and wire tying it to he CHB-13 leg. This can also serve to further ground the tower. Wrap the threads of the CHB-13 with electrical tape to protect them from wet concrete and remove the tape after the concrete is set. Finish concrete with a slight crown to drain water, making sure (1) studs are exposed 3" out of the top of concrete, (2) studs are level across top and (3) studs are indexed according to how tower will hinge up.

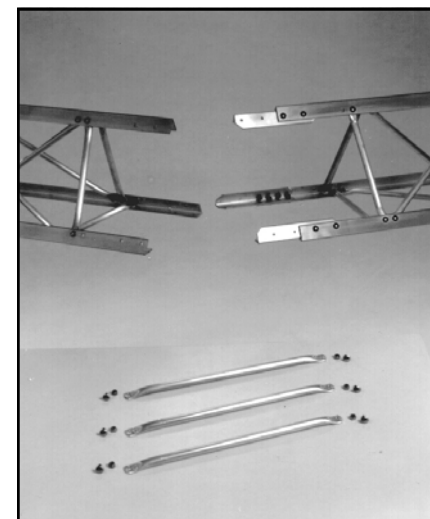

3. HINGED BASE - HB-13: Thread one 7/8 nut down about 2" on each stud of CHB-13 and check that they are level. Next unbolt the tower socket from the hinge plate leaving the hinge bolts in place. Slip the hinge plate over studs and secure with a 7/8 spring lock washer and nut. Final plumbing of the tower can be accomplished by adjusting the leveling nuts on each corner of the tower hinge base after the tower is erected.

4. TOWER CONSTRUCTION - M-13: Lay out the tower sections in the proper order and bolt together. Take care that adjoining tower surfaces are flush. Diagonal braces are bolted in place across section joints. The 1/4-20 carriage bolts require about a 6 foot pound torque. A torque wrench is not necessary. Make sure carriage bolt heads are firmly seated.

5. CONSTRUCTION OF HAZER

These steps are taken while the tower is still laying horizontal on the ground and before the tower is erected. Install wire rope cable thru pulley and down center of tower to the winch . Anchor the cable in the winch as per the drawing on page 8. Prop up the top end of the tower and slide the Hazer down to the the winch. This is the position when the tower is erected.

6. TOWER ERECTION Towers up to 50' may be hinged into vertical position with the help of several good men. Be cautioned to exert equal stress to tower legs to prevent undue stress, twist, or damage to tower. After tower is erected, replumb the tower with main leveling studs on hinge base plate. In some cases, it may be preferable to hire a professional tower erector.

Hinged Base

HB-13/CHB-13
CONCRETE BASE
FRONT VIEW

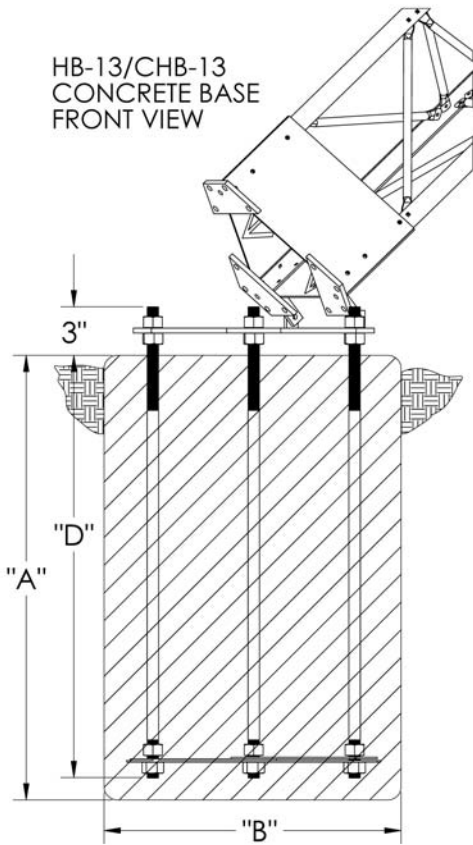

FIG. 2

PARTS LIST - CHB-18/13

QTY	Description
6	CHB-13 Template Strap Brace
3	7/8"-9 x 30" Anchor Bolt
15	7/8"-9 Heavy Hex Nut

Notes:

1. Concrete, 3000 psi minimum
28-day compressive strength.

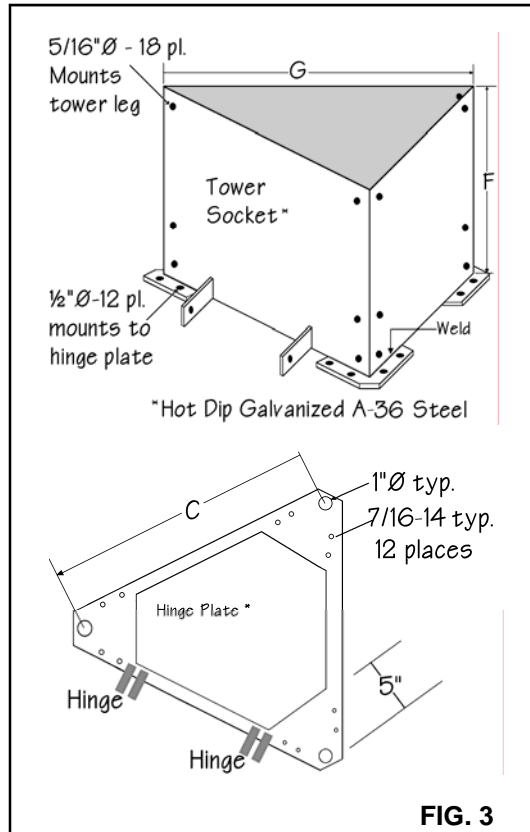
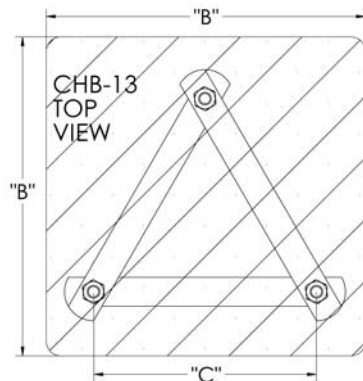

FIG. 3



MODEL	"A"	"B"	Cu. Yds Concrete	"C"
M-13	45"	36"	1.25	15.5"

Accessories

TB-25 Thrust Bearing



Bolt the thrust bearing to the top shelf of the rotator. Ensure your mast is perfectly centered between the rotator and thrust bearing.

Tighten evenly on the mast the six bolts against the mast's surface. Tighten all six lock nuts after all bolts are evenly tight.

MESSANGER LINE KIT

STRAIN RELIEF FOR RF AND ROTATOR CABLES!

The Messenger Line Kit for the Hazer provides an excellent pathway for your rotator control cables and coax cables without worrying about stretch problems. The messenger line itself uses premium quality electrically transparent Kevlar cable.

A Cable clamp is mounted to a leg at the bottom of the tower, and the top brace is bolted to the Hazer itself. A turnbuckle is used at the bottom to loosen the messenger line, allowing the Hazer to be winched upward a little before lowering the Hazer.

Attach your rotator and RF cables to the Messenger Line every 14 inches or so with nylon ties. As you lower your Hazer, the cable bundle simply coils on the ground.

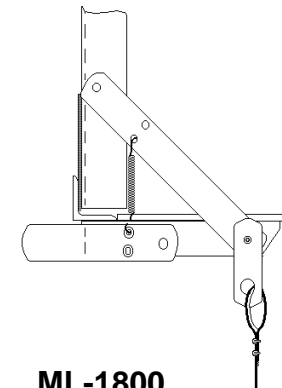

ML-1800
Messenger
Line Kit

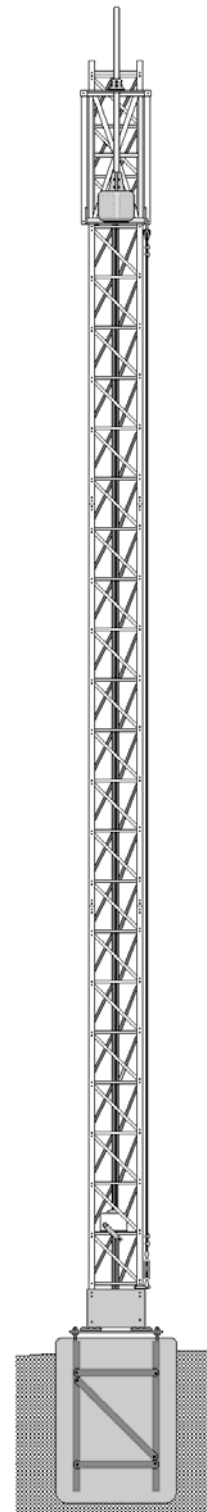
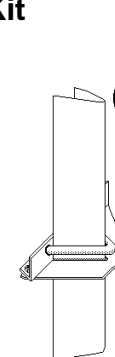

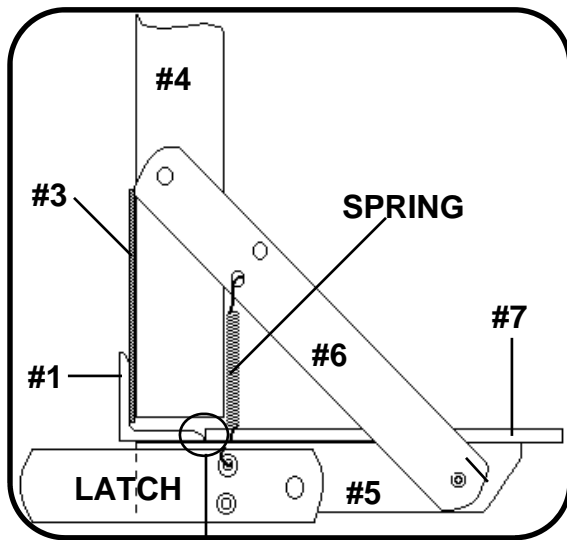

system to achieve a goal of 25 ohms or less ground resistance. Additional ground rods may be necessary to accomplish this. If lightning rod protection is desired the lightning rod is clamped to the highest extreme on the mast. The ground wire is connected to the lightning rod. A small loop is left just above the thrust bearing allowing the mast to rotate. The wire is wire tied to the top of the Hazer and again to the bottom. This ground wire now proceeds to the ground where a turnbuckle tightens it to keep it from blowing in the wind. From there to the ground rod system. Lightning rod Kit part # LR-8406 is available for the purpose. The ground cable is ordered separately.

SPECS. of HB-13 & CHB-13

"A" Concrete Depth	45"
"B" Concrete Width	36"
"C" Footing Section	15.5"
"D" Footing Height	36.5"
"E" Leg Width	1.5"
"F" Socket Height	8"
"G" Socket Width	13.25"
Cubic Yds. concrete	1.25

8. Guy Wire System Before the tower is actually erected the earth screw locations for the guy wires should be plotted and then actually installed. Notice on page 11 that the earth anchor is installed at the same approximate angle as the guy wire attached to it. Digging a small hole in the sod makes getting the anchor to start screwing in easier. A long pipe thru the eye of the earth anchor can serve as leverage. Follow the illustration in using the link, turnbuckle, thimble, and u-bolt clips. The guy wires can serve as pull points when the tower is erected and should be connected to the earth anchors as quickly as possible after the tower is up.

7. Using the Hazer:

7A. You can now install your rotator, mast and antenna(s) on the Hazer. Your rotor should be tested for free rotation, vertical alignment and concentricity with the top bearing plate mast hole.

7B. A thrust bearing (GME Part TB-25) is mounted on the top plate to help support the mast. Use the four bolts provided. Do not use lock washers because the bolts are not too extra long and they could pull a chunk of threads out of the bearing if overtightened. Double check the alignment and concentricity of the mast with the rotor.

7C. Rotor cables and antenna coax should be tied off on a strain relief from the corner of the Hazer using a lug (Part #2). As an added precaution to prevent coax and rotor cables from stretching, a messenger line can be stretched from the corner of the Hazer to a convenient point below and the coax and rotor cables attached to it.

Use nylon ties to secure your cables every foot or so along the entire length of the messenger line below the hazer. (For best results, use the Glen Martin ML-1800 Messenger Line Kit which uses a non-conductive kevlar cable to attach your coax to.)

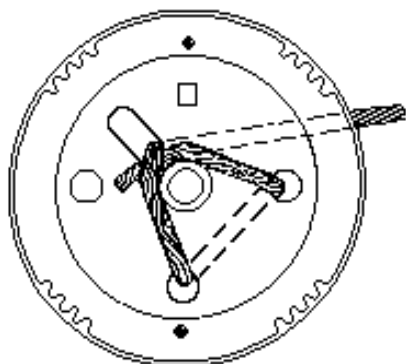
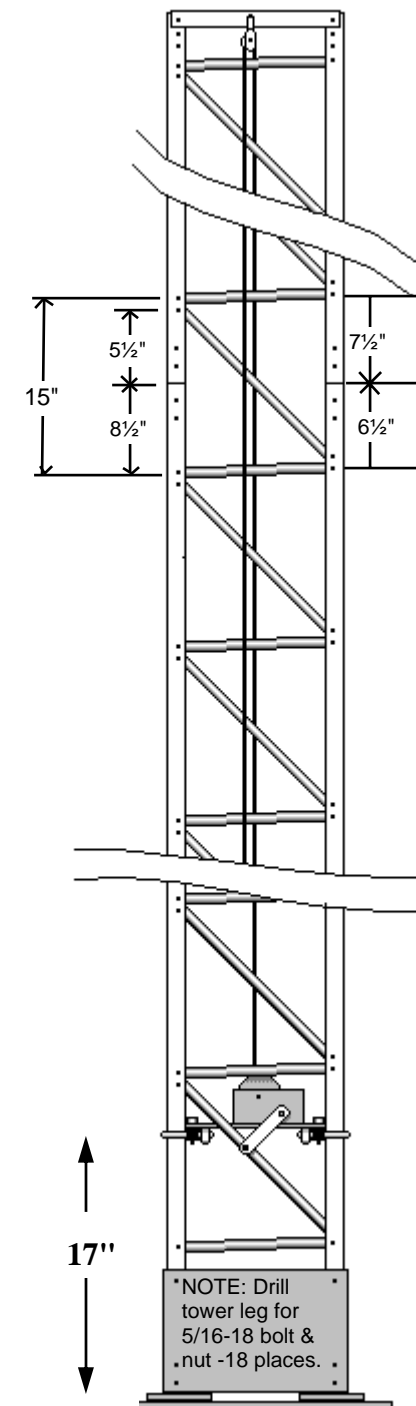

WINCH CABLE ANCHORING METHOD

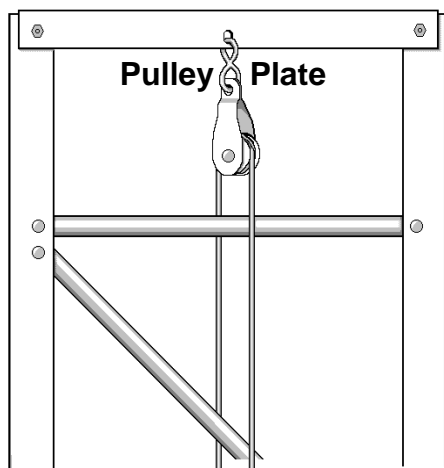

WRS-156 winch cable replacement - *Stainless Steel* 5/32 OD 7x19 2400# break strength.

WR-125 Winch cable replacement - *galvanized steel* 1/8 OD 7x7, 1700# break strength.

7D. The lower left platform corner (Part # 5) includes the safety latch. Tie the pull cord to the "S" hook. To lower the Hazer, first raise the Hazer about an inch and a half, then pull the cord to disengage safety latch while at the same time lowering the Hazer past the "Z" braces of the tower. If the cable were to break or something else happen the hazer would come to rest on the next horizontal brace on the tower. To

prevent unauthorized lowering of the Hazer unit, the winch handle can be removed. TIP: if you prefer a motorized raising and lowering of your antennas, consider using a 1/2" reversible variable speed drill. The chuck clamps down perfectly on the winch handle shaft.

7E. When a yagi beam style antenna is raised and you get near the top set of guy wires they can be temporarily disconnected by completely unscrewing the turnbuckle at the earth screw anchor. As you will see only two of the three guys need to be disconnected. If the third guy happens to be in the direction of the prevailing wind so much the better. This is determined when the CHB-13 is installed, see instruction #2. Once the antenna system is up past the top set of guys they can be reconnected at the turnbuckle. Do not overtighten turnbuckles. About 100 to 175 pounds of pull on each guy wire is all that is necessary. Always remember to **safety tie the turnbuckles** to prevent them from unturning.

8. Grounding Grounding the tower is important. Local or national codes should be complied with. An eight foot copper clad ground rod is supplied. The head of the rod should be driven at least 6 inches below ground level and the ground wire attached to it with GR-4400 ground rod clamp. The other end of the ground wire is connected to the tower with TL-0470 terminal. Ground your

**Ground Wire Clamp
TL-0470**

Copper Ground Wire

HB-13/18

Concrete Base

GROUND PARTS LIST

QTY	DESCRIPTION
1	GR-5080, 8 FT ground rod
2	GR-4400, ground rod clamp
4'	CW-0040, #4 ground wire
1	TL-0470 terminal to mount ground wire to HB-18

Lightning Rod Kit complete with Aluminum 18" tapered point, Mast Clamp, Ground Rod, Ground Rod Clamps and Tower Grounding Lug. Part # **LR-8400** Order sufficient ground wire (listed above) for base of tower to ground

#4 Copper ground wire
Part # **CW-0040**

8-ft copper clad ground rod
Part # **GR-5080**

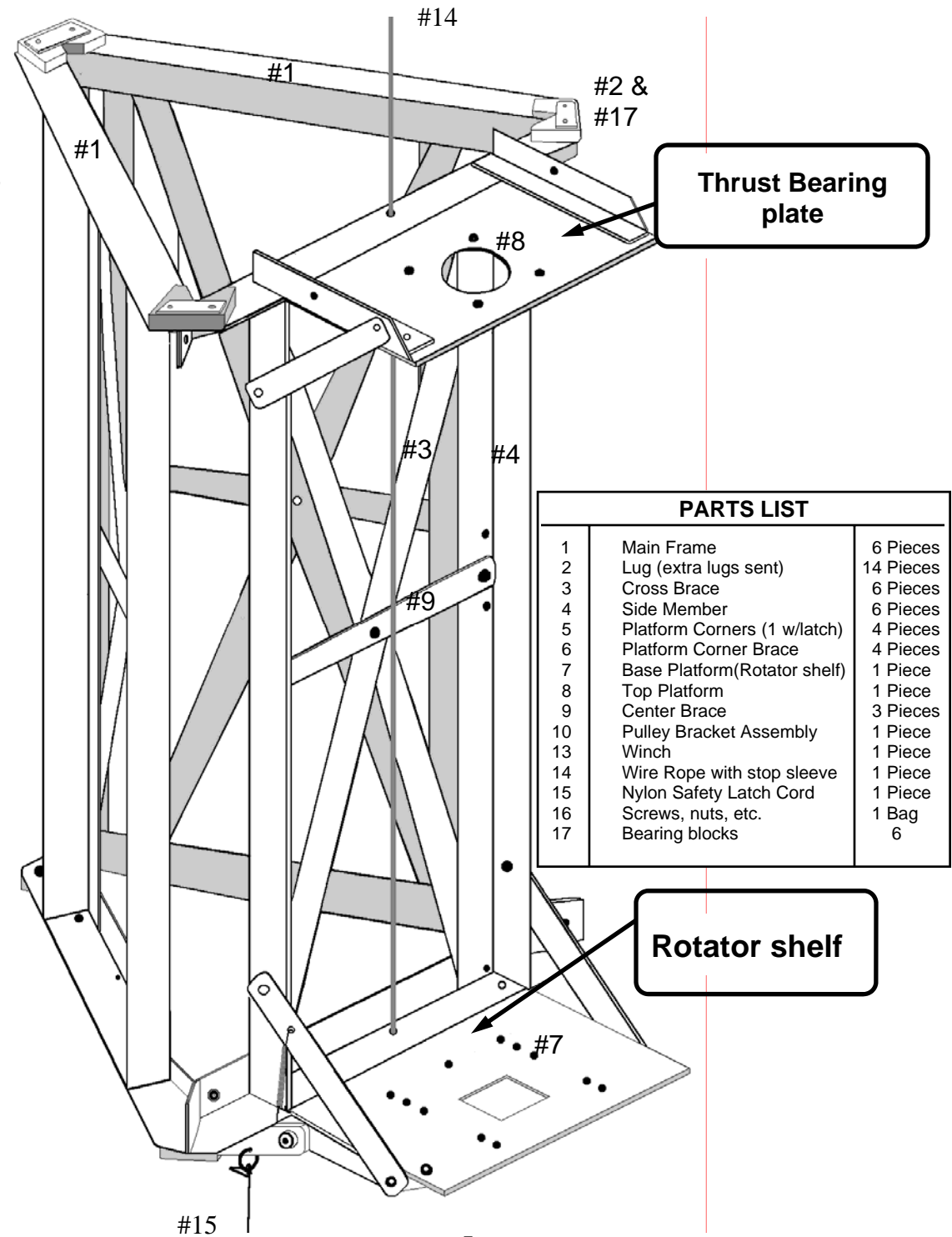

Thrust Bearing plate

Rotator shelf

PARTS LIST

1	Main Frame	6 Pieces
2	Lug (extra lugs sent)	14 Pieces
3	Cross Brace	6 Pieces
4	Side Member	6 Pieces
5	Platform Corners (1 w/latch)	4 Pieces
6	Platform Corner Brace	4 Pieces
7	Base Platform(Rotator shelf)	1 Piece
8	Top Platform	1 Piece
9	Center Brace	3 Pieces
10	Pulley Bracket Assembly	1 Piece
13	Winch	1 Piece
14	Wire Rope with stop sleeve	1 Piece
15	Nylon Safety Latch Cord	1 Piece
16	Screws, nuts, etc.	1 Bag
17	Bearing blocks	6